

TEST REPORT

Report No.: BCTC2304879606-3E

Applicant: MINIX Technology Limited

Product Name: Mini PC

Model/Type reference: RIC SJ64-4W

Tested Date: 2023-04-13 to 2023-04-25

Issued Date: 2023-06-29

Shenzhen BCTC Technology Co., Ltd.



Product Name: Mini PC

Trademark: MINIX

Model/Type reference: RIC SJ64-4W, RIC SJ64-8W, RIC SJ64-16W, RIC SJ64-4U,
RIC SJ64-8U, RIC SJ64-16U, RIC SJ64-MB, RIC SJ64xxxxxxxxx
(x can be 0-9, A-Z, a-z, "-", "_", "/" or blank for marketing purpose)

Prepared For: MINIX Technology Limited

Address: Unit 01, 15/F, Chevalier Commercial Center, No.8 Wang Hoi Road, Kowloon Bay, Kowloon, Hong Kong.

Manufacturer: MINIX Technology Limited

Address: Unit 01, 15/F, Chevalier Commercial Center, No.8 Wang Hoi Road, Kowloon Bay, Kowloon, Hong Kong.

Prepared By: Shenzhen BCTC Technology Co., Ltd.

Address: 1 Floor, Building 2, Huayou Industrial, Yousong Road, Fukang Community, Longhua Street, Longhua District, Shenzhen, Guangdong, China

Sample Received Date: 2023-04-11

Sample tested Date: 2023-04-13 to 2023-04-25

Report No.: BCTC2304879606-3E

Test Standards ETSI EN 301 489-1 V2.2.3 (2019-11)
ETSI EN 301 489-17 V3.2.4 (2020-09)

Test Results PASS

Remark: This is EMC test report.

Tested by:

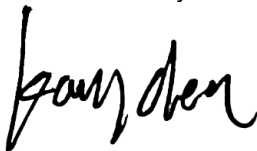

Kang Chen/ Project Handler

Approved by:



Sewen Guo/Reviewer

The test report is effective only with both signature and specialized stamp. This result(s) shown in this report refer only to the sample(s) tested. Without written approval of Shenzhen BCTC Technology Co., Ltd, this report can't be reproduced except in full. The tested sample(s) and the sample information are provided by the client.



Table of Content

	Page
Test Report Declaration	
1. Version	5
2. Test Summary	6
3. Measurement Uncertainty	7
4. Product Information and Test Setup	8
4.1 Product Information	8
4.2 Test Setup Configuration	8
4.3 Support Equipment	8
4.5 Test Mode	8
5. Test Facility and test Instrument Used	10
5.1 Test Facility	10
5.2 Test Instrument Used	10
6. Conducted Emissions	13
6.1 Block Diagram Of Test Setup	13
6.2 Limit	13
6.3 Test procedure	13
6.4 Test Result	14
7. Asymmetric mode conducted emissions	16
7.1 Block Diagram Of Test Setup	16
7.2 Limit	16
7.3 Test procedure	16
7.4 Test Result	17
8. Radiated Emissions Test	18
8.1 Block Diagram Of Test Setup	18
8.2 Limits	18
8.3 Test Procedure	19
8.4 Test Results	20
9. Harmonic current emission(H)	24
9.1 Block Diagram of Test Setup	24
9.2 Limit	24
9.3 Test Procedure	24
9.4 Test Results	24
10. Voltage Fluctuations & Flicker (F)	25
10.1 Block Diagram of Test Setup	25
10.2 Limit	25
10.3 Test Procedure	25
10.4 Test Results	26
11. Immunity Test of General the Performance Criteria	27
12. Electrostatic Discharge (ESD)	28
12.1 Test Specification	28
12.2 Block Diagram of Test Setup	28
12.3 Test Procedure	28
12.4 Test Results	29
13. Continuous RF Electromagnetic Field Disturbances(RS)	30
13.1 Test Specification	30

C T
 30
 PPR
 检测

13.2	Block Diagram of Test Setup	30
13.3	Test Procedure	31
13.4	Test Results	31
14.	Electrical fast transients/burst (EFT)	32
14.1	Test Specification.....	32
14.2	Block Diagram of EUT Test Setup	32
14.3	Test Procedure	32
14.4	Test Results	33
15.	Surges Immunity Test	34
15.1	Test Specification.....	34
15.2	Block Diagram of EUT Test Setup	34
15.3	Test Procedure	34
15.4	Test Result.....	35
16.	Continuous Induced RF Disturbances (CS)	36
16.1	Test Specification.....	36
16.2	Block Diagram of EUT Test Setup	36
16.3	Test Procedure	36
16.4	Test Result.....	37
17.	Voltage dips and interruptions (DIPS)	38
17.1	Test Specification.....	38
17.2	Block Diagram of EUT Test Setup	38
17.3	Test Procedure	38
17.4	Test Result.....	39
18.	EUT Photographs.....	40
19.	EUT Test Setup Photographs.....	40

ECHA
BCTC
OVER
科学

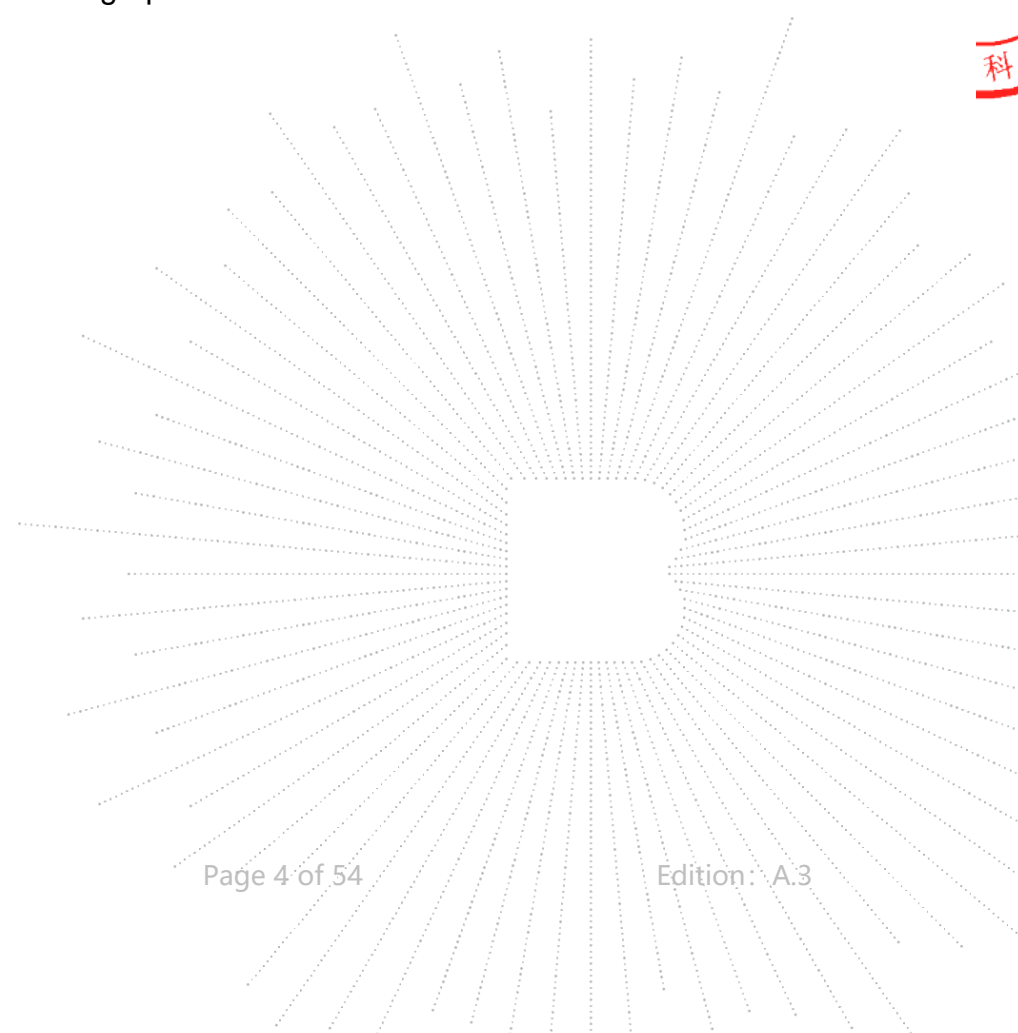

1. Version

Report No.	Issue Date	Description	Approved
BCTC2304879606-3E	2023-06-29	Original	Valid

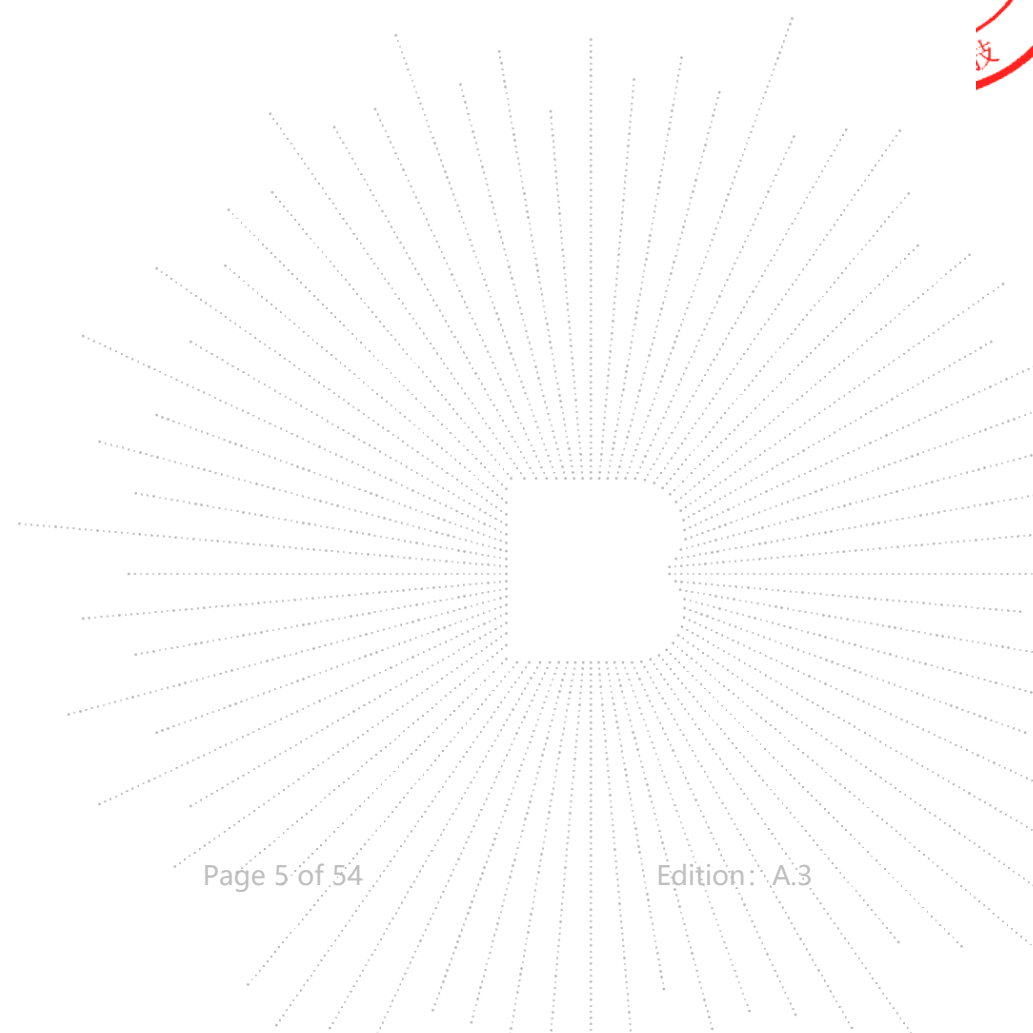

2. Test Summary

The Product has been tested according to the following specifications:

Emission			
Standard		Test Item	Test result
ETSI EN 301 489-1	8.2	Radiated Emissions	Pass
	8.7	Asymmetric mode conducted emissions	Pass
	8.4	Conducted emissions from the AC mains power ports	Pass
	8.5	Harmonic current emission(H)	N/A
	8.6	Voltage fluctuations & flicker(F)	Pass
	9.2	Continuous RF electromagnetic field disturbances(RS)	Pass [#]
	9.3	Electrostatic Discharge	Pass
	9.4	Fast Transients, Common Mode	Pass
	9.5	Continuous induced RF disturbances (CS)	Pass
	9.6	Transient and Surges in the Vehicular Environment	N/A
	9.7	Voltage dips and interruptions (DIPS)	Pass
	9.8	Surges	Pass

Remark:

- The N/A is an abbreviation for not applicable.
- "#" indicates the testing item(s) was (were) fulfilled by subcontracted lab.

BCTC CO., LTD

3. Measurement Uncertainty

Where relevant, the following measurement uncertainty levels have been estimated for tests performed on the Product as specified in CISPR 16-4-2. This uncertainty represents an expanded uncertainty expressed at approximately the 95% confidence level using a coverage factor of $k=2$.

Test item	Value (dB)
Conducted Emission (150kHz-30MHz)	3.20
Radiated Emission(30MHz~1GHz)	4.80
Radiated Emission(1GHz~6GHz)	4.90

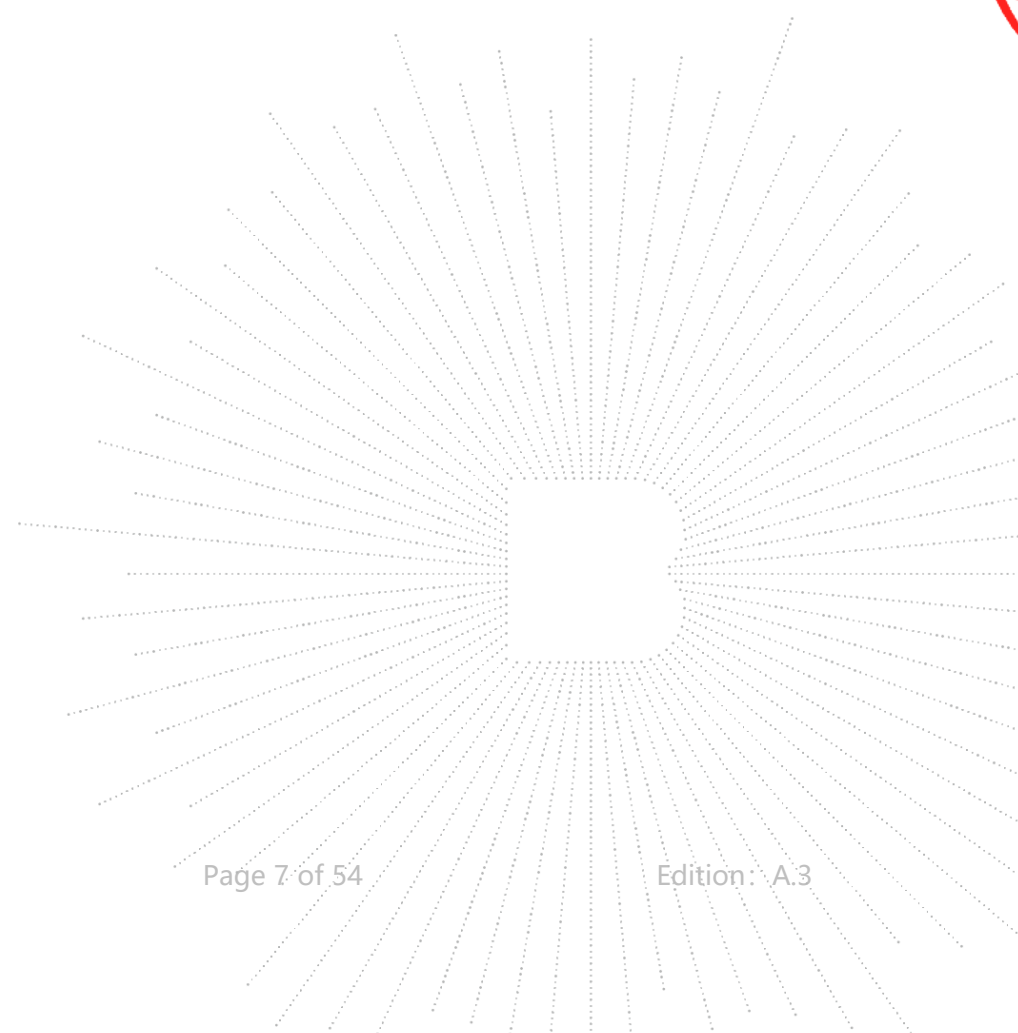

4. Product Information and Test Setup

4.1 Product Information

Model/Type reference:	RIC SJ64-4W, RIC SJ64-8W, RIC SJ64-16W, RIC SJ64-4U, RIC SJ64-8U, RIC SJ64-16U, RIC SJ64-MB, RIC SJ64xxxxxxxx (x can be 0-9, A-Z, a-z, "-", "_", "/" or blank for marketing purpose)
Model differences:	Our production units bearing the following model numbers are identical in circuitry and electrical, mechanical and physical construction; The difference is only in model names.
Antenna installation:	External antenna
Antenna Gain:	0 dBi
Ratings:	AC 100-240V/50-60Hz
Adapter:	Input: AC 100-240V/50-60Hz Output: 19V/3.42A

4.2 Test Setup Configuration

See test photographs attached in EUT test setup photographs for the actual connections between Product and support equipment.

4.3 Support Equipment

No.	Device Type	Brand	Model	Series No.	Note
1.	---	---	--	---	---

Notes

- All the equipment/cables were placed in the worst-case configuration to maximize the emission during the test.
- Grounding was established in accordance with the manufacturer's requirements and conditions for the intended use.

4.5 Test Mode

Investigation has been done on all the possible configurations for searching the worst cases. The following table is a list of the test modes shown in this test report.

Test Mode	
Mode 1:	WIFI Link/BT Link
Mode 2:	Standby



Test item	Test Mode	Test Voltage
Conducted emissions from the AC mains power ports (150KHz-30MHz) Class B	Mode 1*	AC 230V/50Hz
Asymmetric mode conducted emissions	Mode 1*	AC 230V/50Hz
Radiated emissions(30MHz-6GHz) Class B	Mode 1*	AC 230V/50Hz
Voltage fluctuations & flicker(F)	Mode 1	AC 230V/50Hz
Electrostatic discharge (ESD) <input checked="" type="checkbox"/> Air Discharge: $\pm 2,4,8\text{Kv}$ <input checked="" type="checkbox"/> Contact Discharge: $\pm 2,4\text{kV}$ <input checked="" type="checkbox"/> HCP & VCP: $\pm 2,4\text{kV}$	Mode 1	AC 230V/50Hz
Continuous RF electromagnetic field disturbances(RS) <input checked="" type="checkbox"/> 80MHz-6000MHz , 3V/m,80% Front, Rear, Left, Right H/V	Mode 1	AC 230V/50Hz
Electrical fast transients/burst (EFT) B <input checked="" type="checkbox"/> 1kV AC(Input) <input type="checkbox"/> 0.5kV DC(Input) <input checked="" type="checkbox"/> 0.5kV signal,Telec,control	Mode 1	AC 230V/50Hz
Surges B <input checked="" type="checkbox"/> 1kV Line-Line, <input checked="" type="checkbox"/> 2kV Line-PE, N-PE <input type="checkbox"/> 0.5kVDC(Input) <input checked="" type="checkbox"/> 1KV, <input type="checkbox"/> 4KV signal,Telec, control Line-Line:90°+1kV,270°-1kV Line-PE:90°+2kV,270°-2kV N-PE:90°-2kV,270°+2kV	Mode 1	AC 230V/50Hz
Continuous induced RF disturbances (CS) A 0.15MHz - 80MHz 3V <input checked="" type="checkbox"/> AC(Input) <input type="checkbox"/> DC(Input) <input checked="" type="checkbox"/> signal, Telec, control	Mode 1	AC 230V/50Hz
Voltage dips and interruptions (DIPS) Less 5% 0.5P 10ms B 70% 25P 500ms C Voltage Interruptions less5% 250P 5000ms C	Mode 1	AC 230V/50Hz
All test mode were tested and passed, only Conducted Emissions, Radiated Emissions shows (*) is the worst case mode which were recorded in this report.		

C T
 30
 PPR
 字测

5. Test Facility and test Instrument Used

5.1 Test Facility

All measurement facilities used to collect the measurement data are located:

Shenzhen BCTC Technology Co., Ltd.

Address:1 Floor, Building 2, Huayou Industrial, Yousong Road, Fukang Community, Longhua Street, Longhua District, Shenzhen, Guangdong, China.

Shenzhen BCTC Testing Co., Ltd.

Address:1-2/F., Building B, Pengzhou Industrial Park, No.158, Fuyuan 1st Road, Zhancheng, Fuhai Subdistrict, Bao'an District, Shenzhen, Guangdong, China.

The site and apparatus are constructed in conformance with the requirements of ANSI C63.4 and CISPR 16-1-1 other equivalent standards.

5.2 Test Instrument Used

Conducted emissions Test					
Equipment	Manufacturer	Model#	Serial#	Last Cal.	Next Cal.
Receiver	R&S	ESCI	101421	2022-06-01	2023-05-31
AMN	SCHWHRZBECK	NNBM8127	8127739	2022-06-01	2023-05-31
Pulse Limiter	SCHWHRZBECK	VTSD 9561-F-N	00547	2022-06-01	2023-05-31
Software	EZ-EMC	Ver.EMC-CON 3A1	/	/	/

Radiated disturbance					
Equipment	Manufacturer	Model#	Serial#	Last Cal.	Next Cal.
Broadband antenna	SCHWHRZBECK	VULB9160	3369	2022-06-06	2023-06-05
Receiver	R&S	ESPI	1164.6407. 07	2022-06-01	2023-05-31
Preamplifier	SCHWHRZBECK	BBV9743	/	2022-06-01	2023-05-31
Horn antenna	SCHWARZBECK	BBHA 9120 D	2792	2022-12-23	2023-12-22
Preamplifier	EMC INSTRUMENTS CORPORATION	EMC0518A45SE E	EMT-SZ22 33	2022-11-21	2023-11-20
RF cable 1#	SKET	5M	#10	2022-12-23	2023-12-22
RF cable 2#	/	5M	18038628	2022-12-23	2023-12-22
RF cable 3#	/	8.5M	18038631	2022-12-23	2023-12-22
RF cable 4#	/	9M	18038626	2022-12-23	2023-12-22
Software	EZ-EMC	Ver.FA-03A2	/	/	/

Harmonic / Flicker Test					
Equipment	Manufacturer	Model#	Serial#	Last Cal.	Next Cal.
Harmonic tester	KIKUSUI	KHA1000	VA002162	2022-06-07	2023-06-06
Linear impedance network	KIKUSUI	LIN1020JF	UL001611	2022-06-01	2023-05-31
Multi outlet unit	KIKUSUI	0T01-RHA	N/A	2022-06-07	2023-06-06
Power supply network	KIKUSUI	PCR4000M	UK001879	2022-06-01	2023-05-31
Software	KIKUSUI	Ver3.6.1.00	/	/	

Electrostatic discharge Test					
Equipment	Manufacturer	Model#	Serial#	Last Cal.	Next Cal.
Electrostatic discharge generator	3C TEST	EDS 30V	ES0121614	2022-06-02	2023-06-01

Continuous RF Electromagnetic Field Disturbances Test (Shenzhen BCTC Testing Co., Ltd.)					
Equipment	Manufacturer	Model#	Serial#	Last Cal.	Next Cal.
Power meter	Keysight	E4419	\	2022-05-24	2023-05-23
Power sensor	Keysight	E9300A	\	2022-05-24	2023-05-23
Power sensor	Keysight	E9300A	\	2022-05-24	2023-05-23
Amplifier	SKET	HAP_801000-250W	\	2022-05-24	2023-05-23
Amplifier	SKET	HAP_0103-75W	\	2022-05-24	2023-05-23
Amplifier	SKET	HAP_0306-50W	\	2022-05-24	2023-05-23
Stacked double Log.-Per. Antenna	Schwarzbeck	STLP 9129	\	\	\
Field Probe	Narda	EP-601	\	2022-05-30	2023-05-29
Signal Generator	Agilent	N5181A	MY50143748	2022-05-24	2023-05-23
Communication test set	R&S	CMW500	157483	2023-03-15	2024-03-14
Software	SKET	EMC-S	1.2.0.18	\	\



Fast transients immunity Test					
Equipment	Manufacturer	Model#	Serial#	Last Cal.	Next Cal.
Fast pulse generator	Prima	EFT61004AG	PR14054467	2022-06-01	2023-05-31
Coupling forceps	Prima	EFT61004AG	BCTC009E	2022-06-01	2023-05-31

Surges immunity Test					
Equipment	Manufacturer	Model#	Serial#	Last Cal.	Next Cal.
Power line lightning strike generator	Prima	SUG61005BX	PR12045446	2022-05-10	2023-05-09
Single phase transformer	Prima	JMB-3KVA	LL-PLM1407	2022-06-01	2023-05-31
Communication test set	R&S	CMW500	157483	2023-03-15	2024-03-14

Injected currents immunity Test					
Equipment	Manufacturer	Model#	Serial#	Last Cal.	Next Cal.
CS signal generator	SCHLODER	CDG6000	126B1281	2022-06-01	2023-05-31
Injection forceps	SCHLODER	EMCL-20	132A1214/2015	2022-06-01	2023-05-31
CDN	SCHLODER	CDN-M2+3	A2210320/2015	2022-06-01	2023-05-31
6dB Attenuator	N/A	CDG60100	201411010015	2022-06-01	2023-05-31
Software	HUBERT	Version 1.3.0(04.02.2014)	126B1300	/	/
Communication test set	R&S	CMW500	157483	2023-03-15	2024-03-14

Voltage dips and interruptions immunity Test					
Equipment	Manufacturer	Model#	Serial#	Last Cal.	Next Cal.
Voltage drop tester	Prima	DRP61011AG	PR14086284	2022-06-01	2023-05-31



6. Conducted Emissions

6.1 Block Diagram Of Test Setup

For mains ports:

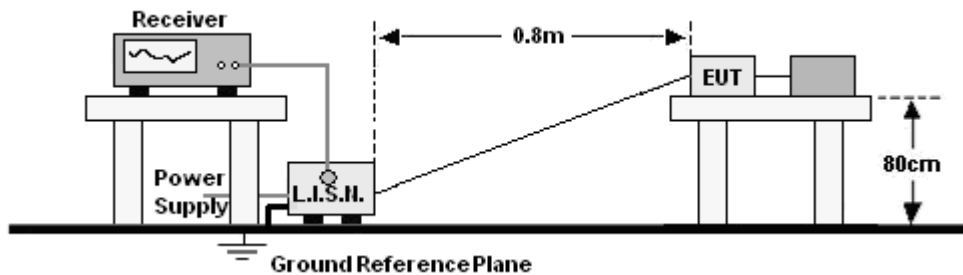

6.2 Limit

Limits for Conducted emissions at the mains ports of Class B MME

Frequency range MHz)	Limits dB(μ V)	
	Quasi-peak	Average
0,15 to 0,50	66 to 56*	56 to 46*
0,50 to 5	56	46
5 to 30	60	50

Notes: 1. *Decreasing linearly with logarithm of frequency.
2. The lower limit shall apply at the transition frequencies.

6.3 Test procedure

For mains ports:

- The Product was placed on a nonconductive table 0.8 m above the horizontal ground reference plane, and 0.4 m from the vertical ground reference plane, and connected to the main through Line Impedance Stability Network (L.I.S.N).
- The RBW of the receiver was set at 9 kHz in 150 kHz ~ 30MHz with Peak and AVG detector in Max Hold mode. Run the receiver's pre-scan to record the maximum disturbance generated from Product in all power lines in the full band.
- For each frequency whose maximum record was higher or close to limit, measure its QP and AVG values and record.

6.4 Test Result

Temperature:	26 °C	Relative Humidity:	54%
Pressure:	101KPa	Phase :	L
Test Mode:	Mode 1	Test Voltage :	AC 230V/50Hz

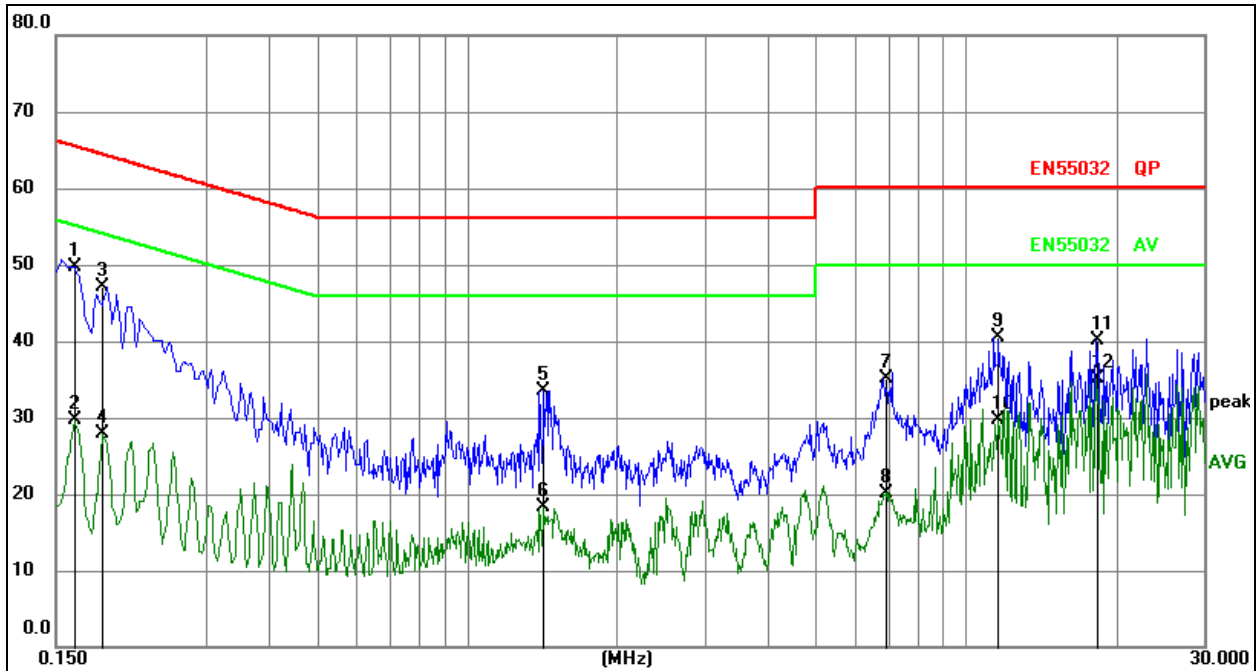

Remark:

1. All readings are Quasi-Peak and Average values.
2. Factor = Insertion Loss + Cable Loss.
3. Measurement = Reading Level + Correct Factor
4. Over = Measurement - Limit

No.	Mk.	Freq. MHz	Reading Level	Correct Factor dB	Measure- ment dBuV	Limit dBuV	Over dB	Detector	Comment
1		0.1633	39.53	10.23	49.76	65.29	-15.53	QP	
2		0.1633	19.53	10.23	29.76	55.29	-25.53	AVG	
3		0.1853	36.82	10.24	47.06	64.24	-17.18	QP	
4		0.1853	17.67	10.24	27.91	54.24	-26.33	AVG	
5		1.4256	23.42	10.17	33.59	56.00	-22.41	QP	
6		1.4256	8.16	10.17	18.33	46.00	-27.67	AVG	
7		6.9141	24.72	10.38	35.10	60.00	-24.90	QP	
8		6.9141	9.81	10.38	20.19	50.00	-29.81	AVG	
9		11.6208	30.21	10.39	40.60	60.00	-19.40	QP	
10		11.6208	19.36	10.39	29.75	50.00	-20.25	AVG	
11		18.2316	29.55	10.50	40.05	60.00	-19.95	QP	
12	*	18.2316	24.58	10.50	35.08	50.00	-14.92	AVG	

Temperature:	26 °C	Relative Humidity:	54%
Pressure:	101KPa	Phase :	N
Test Mode:	Mode 1	Test Voltage :	AC 230V/50Hz

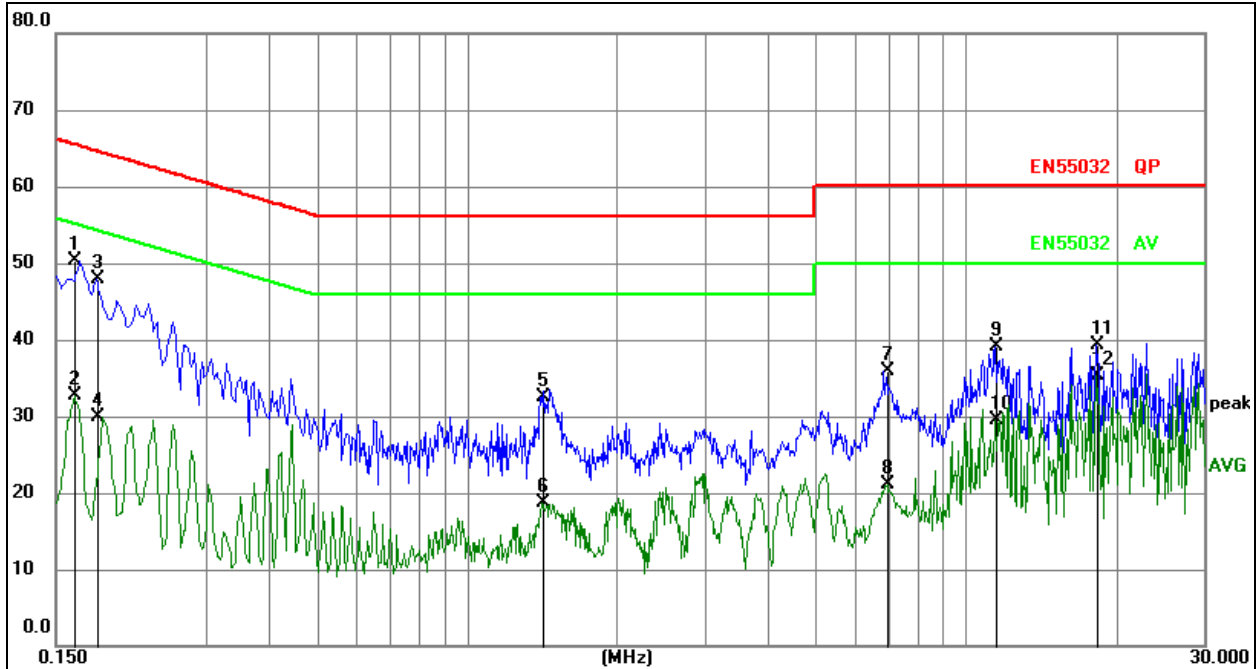
Remark:

1. All readings are Quasi-Peak and Average values.
2. Factor = Insertion Loss + Cable Loss.
3. Measurement = Reading Level + Correct Factor
4. Over = Measurement - Limit

No. Mk.	Freq. MHz	Reading Level	Correct Factor dB	Measure- ment dBuV	Limit dBuV	Over dB	Detector	Comment
1	0.1635	40.05	10.23	50.28	65.28	-15.00	QP	
2	0.1635	22.57	10.23	32.80	55.28	-22.48	AVG	
3	0.1814	37.62	10.24	47.86	64.42	-16.56	QP	
4	0.1814	19.75	10.24	29.99	54.42	-24.43	AVG	
5	1.4144	22.37	10.17	32.54	56.00	-23.46	QP	
6	1.4144	8.63	10.17	18.80	46.00	-27.20	AVG	
7	6.9539	25.57	10.38	35.95	60.00	-24.05	QP	
8	6.9539	10.69	10.38	21.07	50.00	-28.93	AVG	
9	11.4629	28.73	10.39	39.12	60.00	-20.88	QP	
10	11.4629	19.19	10.39	29.58	50.00	-20.42	AVG	
11	18.2443	28.74	10.50	39.24	60.00	-20.76	QP	
12 *	18.2443	24.75	10.50	35.25	50.00	-14.75	AVG	

7. Asymmetric mode conducted emissions

7.1 Block Diagram Of Test Setup

For asymmetric mode ports:

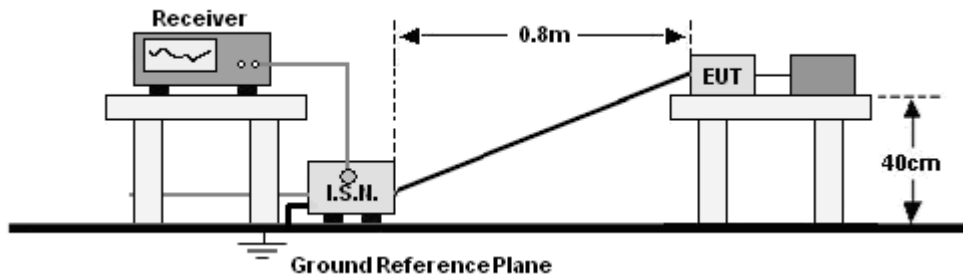

7.2 Limit

Limits for asymmetric mode conducted emissions of Class B MME

Frequency range (MHz)	Limits dB(μ V)	
	Quasi-peak	Average
0,15 to 0,50	84-74*	74-64*
0,50 to 30	74	64

Notes: *Decreasing linearly with logarithm of frequency.

7.3 Test procedure

For asymmetric mode ports:

- The Product was placed on a non-conductive table 0.8 m above the horizontal ground reference plane, and 0.4 m from the vertical ground reference plane, and connected to the associated port through voltage probe.
- The RBW of the receiver was set at 9 kHz in 150 kHz ~ 30MHz with Peak and AVG detector in Max Hold mode. Run the receiver's pre-scan to record the maximum disturbance generated from Product in all power lines in the full band.
- For each frequency whose maximum record was higher or close to limit, measure its QP and AVG values and record.

7.4 Test Result

Temperature:	26 °C	Relative Humidity:	54%
Pressure:	101kPa	Phase :	/
Test Voltage :	AC 230V/50Hz	Test Mode:	Mode 1

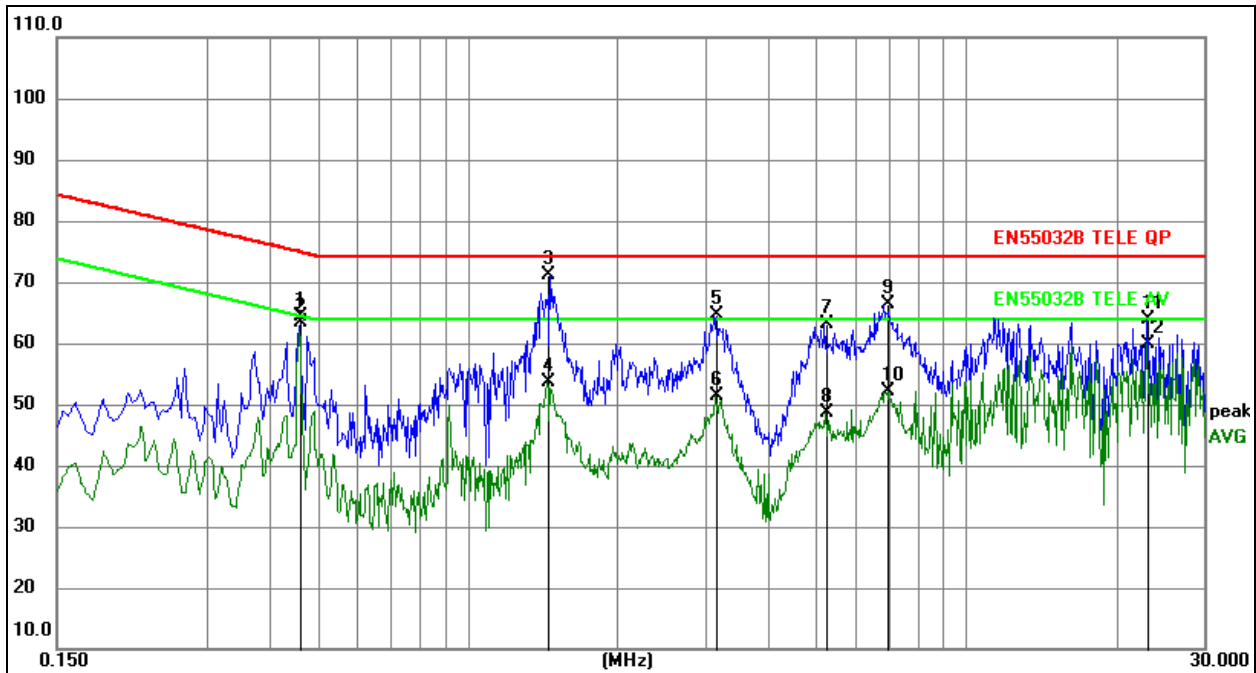

Remark:

1. All readings are Quasi-Peak and Average values.
2. Factor = Insertion Loss + Cable Loss.

No. Mk.	Freq. MHz	Reading Level dB	Correct Factor dB	Measure- ment dBuV	Limit dBuV	Over dB	Detector	Comment
1	0.4605	54.66	9.60	64.26	74.68	-10.42	QP	
2 *	0.4605	53.76	9.60	63.36	64.68	-1.32	AVG	
3	1.4460	61.43	9.71	71.14	74.00	-2.86	QP	
4	1.4460	43.80	9.71	53.51	64.00	-10.49	AVG	
5	3.1560	55.06	9.67	64.73	74.00	-9.27	QP	
6	3.1560	41.64	9.67	51.31	64.00	-12.69	AVG	
7	5.2350	53.45	9.69	63.14	74.00	-10.86	QP	
8	5.2350	38.86	9.69	48.55	64.00	-15.45	AVG	
9	6.9630	56.50	9.95	66.45	74.00	-7.55	QP	
10	6.9630	42.13	9.95	52.08	64.00	-11.92	AVG	
11	23.1270	53.85	10.08	63.93	74.00	-10.07	QP	
12	23.1270	49.71	10.08	59.79	64.00	-4.21	AVG	

8. Radiated Emissions Test

8.1 Block Diagram Of Test Setup

30MHz ~ 1GHz:

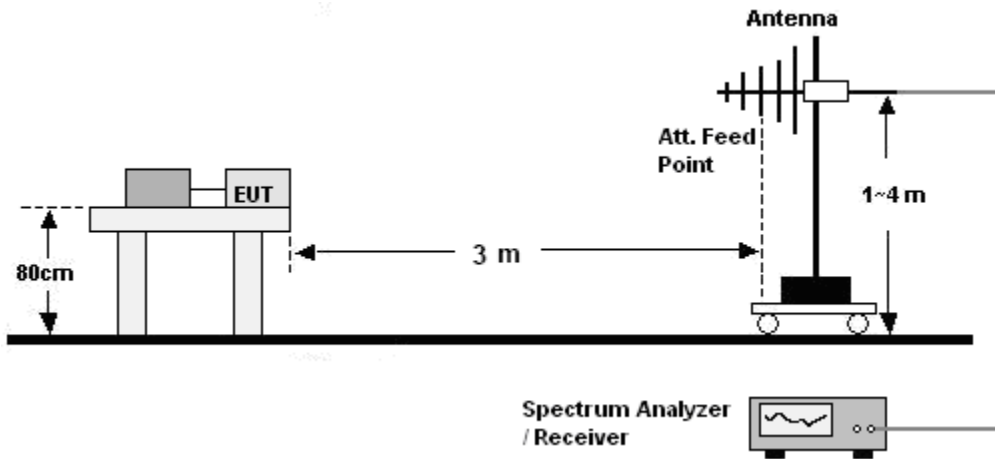

Above 1GHz:

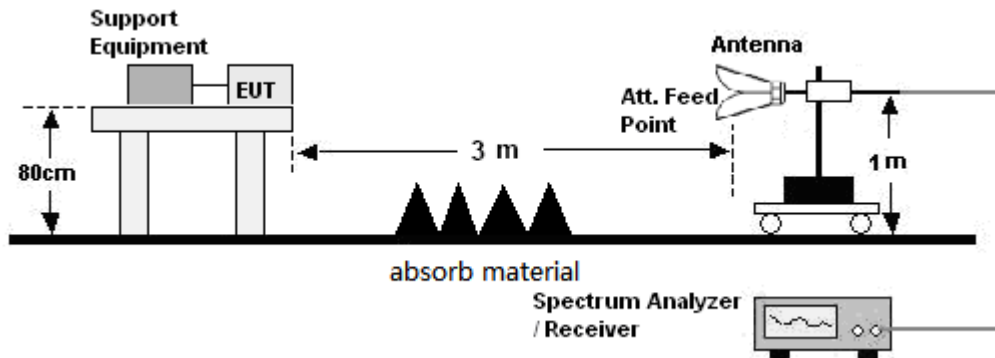

8.2 Limits

Limits for radiated disturbance of Class B MME

Frequency (MHz)	Quasi-peak limits at 3m dB(μ V/m)	
30-230	40	
230-1000	47	
Frequency (GHz)	limit above 1G at 3m dB(μ V/m)	
	Average	peak
1-3	50	70
3-6	54	74

Note: The lower limit shall apply at the transition frequencies.

8.3 Test Procedure

30MHz ~ 1GHz:

- a. The Product was placed on the nonconductive turntable 0.8m above the ground in a semi anechoic chamber.
- b. Set the spectrum analyzer/receiver in Peak detector, Max Hold mode, and 120 kHz RBW. Record the maximum field strength of all the pre-scan process in the full band when the antenna is varied between 1~4 m in both horizontal and vertical, and the turntable is rotated from 0 to 360 degrees.
- c. For each frequency whose maximum record was higher or close to limit, measure its QP value: vary the antenna's height and rotate the turntable from 0 to 360 degrees to find the height and degree where Product radiated the maximum emission, then set the test frequency analyzer/receiver to QP Detector and specified bandwidth with Maximum Hold Mode, and record the maximum value.

Above 1GHz:

- a. The Product was placed on the non-conductive turntable 0.8 m above the ground in a full anechoic chamber..
- b. Set the spectrum analyzer/receiver in Peak detector, Max Hold mode, and 1MHz RBW. Record the maximum field strength of all the pre-scan process in the full band when the antenna is varied in both horizontal and vertical, and the turntable is rotated from 0 to 360 degrees.
- c. For each frequency whose maximum record was higher or close to limit, measure its AV value: rotate the turntable from 0 to 360 degrees to find the degree where Product radiated the maximum emission, then set the test frequency analyzer/receiver to AV value and specified bandwidth with Maximum Hold Mode, and record the maximum value.

SHENZHEN

8.4 Test Results

Below 1GHz

Temperature:	26 °C	Relative Humidity:	54%
Pressure:	101KPa	Phase :	Horizontal
Test Mode:	Mode 1	Test Voltage :	AC 230V/50Hz

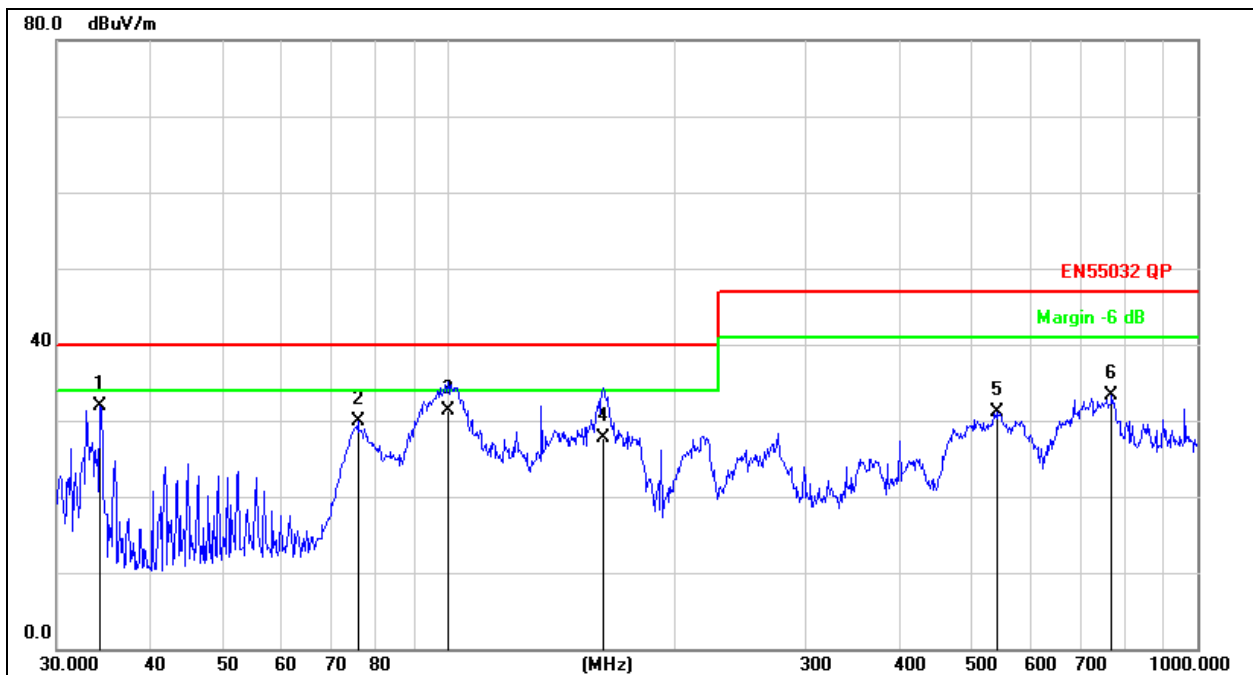

Remark:

- Factor = Antenna Factor + Cable Loss – Pre-amplifier.
- Measurement = Reading Level + Correct Factor
- Over = Measurement - Limit

No.	Mk.	Freq.	Reading Level	Correct Factor	Measurement	Limit	Over	Antenna Height	Table Degree	
		MHz	dBuV	dB	dBuV/m	dB/m	dB	cm	degree	Comment
1	*	34.2760	40.18	-8.29	31.89	40.00	-8.11	QP		
2		75.7114	41.27	-11.35	29.92	40.00	-10.08	QP		
3		99.8777	41.37	-9.97	31.40	40.00	-8.60	QP		
4		160.9089	34.09	-6.39	27.70	40.00	-12.30	QP		
5		541.3725	30.94	0.20	31.14	47.00	-15.86	QP		
6		768.7481	28.73	4.67	33.40	47.00	-13.60	QP		

Temperature:	26 °C	Relative Humidity:	54%
Pressure:	101KPa	Phase :	Vertical
Test Mode:	Mode 1	Test Voltage :	AC 230V/50Hz

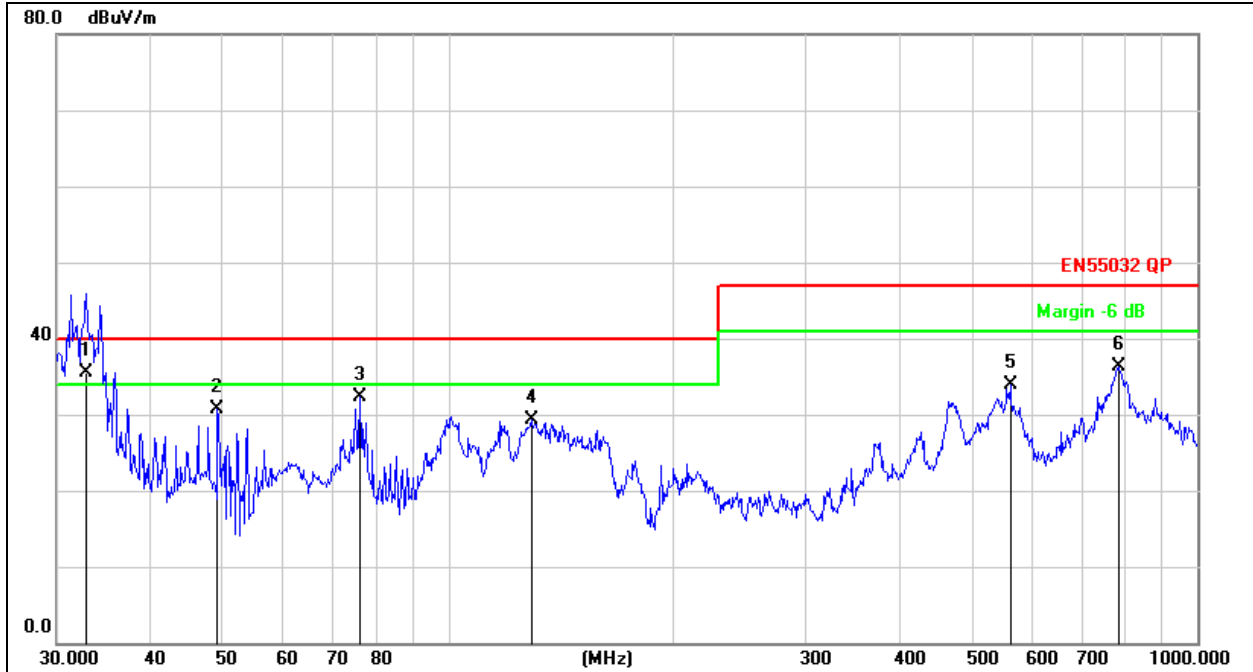

- Remark:
- Factor = Antenna Factor + Cable Loss – Pre-amplifier.
 - Measurement = Reading Level + Correct Factor
 - Over = Measurement - Limit

No.	Mk.	Freq. MHz	Reading Level dBuV	Correct Factor dB	Measure- ment dBuV/m	Limit dB/m	Over dB	Detector	Antenna Height cm	Table Degree	Comment
1	*	32.8637	43.85	-8.25	35.60	40.00	-4.40	QP			
2		49.1865	39.67	-9.00	30.67	40.00	-9.33	QP			
3		76.2442	43.77	-11.39	32.38	40.00	-7.62	QP			
4		129.0146	36.64	-7.41	29.23	40.00	-10.77	QP			
5		562.6624	33.17	0.67	33.84	47.00	-13.16	QP			
6		785.0934	31.48	4.75	36.23	47.00	-10.77	QP			

Above 1GHz

Temperature:	26 °C	Relative Humidity:	54%
Pressure:	101KPa	Phase :	Horizontal
Test Mode:	Mode 1	Test Voltage :	AC 230V/50Hz

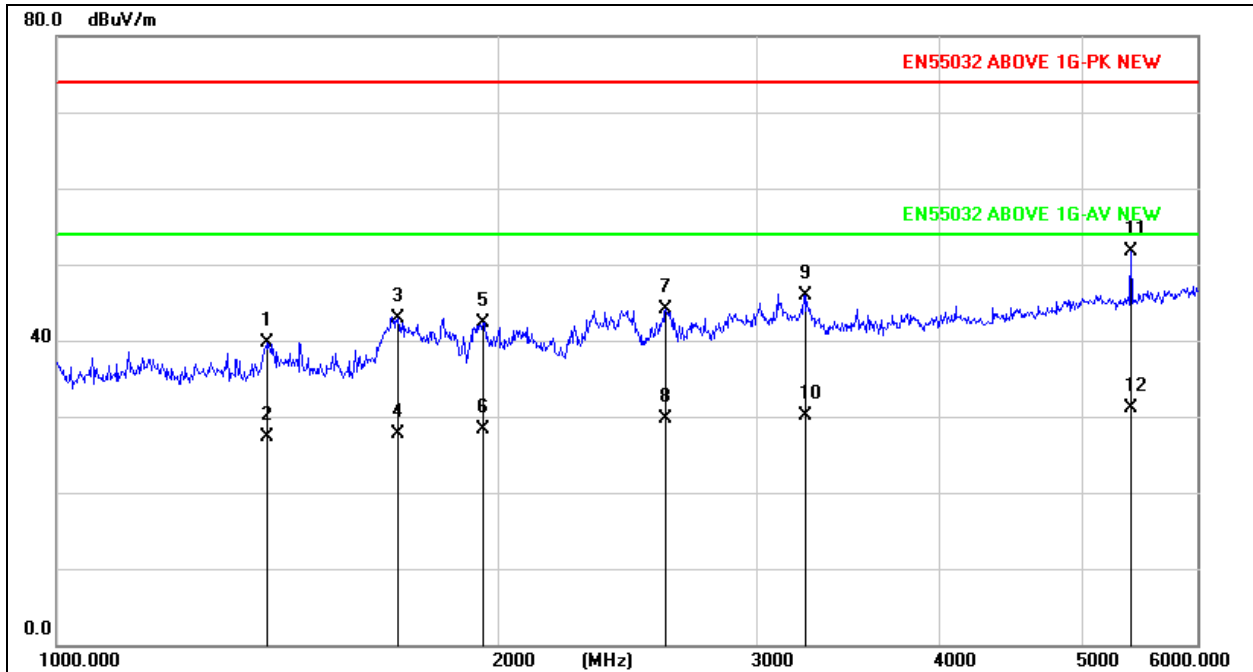

Remark:

1. Factor = Antenna Factor + Cable Loss – Pre-amplifier.
2. Measurement = Reading Level + Correct Factor
3. Over = Measurement - Limit

No. Mk.	Freq. MHz	Reading Level dBuV	Correct Factor dB	Measure- ment dBuV/m	Limit dB/m	Over dB	Detector	Antenna Height cm	Table Degree degree	Comment
1	1393.022	59.30	-19.67	39.63	74.00	-34.37	peak			
2	1393.022	46.97	-19.67	27.30	54.00	-26.70	AVG			
3	1708.706	61.84	-19.01	42.83	74.00	-31.17	peak			
4	1708.706	46.63	-19.01	27.62	54.00	-26.38	AVG			
5	1954.468	60.79	-18.50	42.29	74.00	-31.71	peak			
6	1954.468	46.83	-18.50	28.33	54.00	-25.67	AVG			
7	2603.351	59.81	-15.75	44.06	74.00	-29.94	peak			
8	2603.351	45.40	-15.75	29.65	54.00	-24.35	AVG			
9	3239.420	59.31	-13.45	45.86	74.00	-28.14	peak			
10	3239.420	43.55	-13.45	30.10	54.00	-23.90	AVG			
11 *	5407.773	60.01	-8.27	51.74	74.00	-22.26	peak			
12	5407.773	39.47	-8.27	31.20	54.00	-22.80	AVG			

Temperature:	26 °C	Relative Humidity:	54%
Pressure:	101KPa	Phase :	Vertical
Test Mode:	Mode 1	Test Voltage :	AC 230V/50Hz

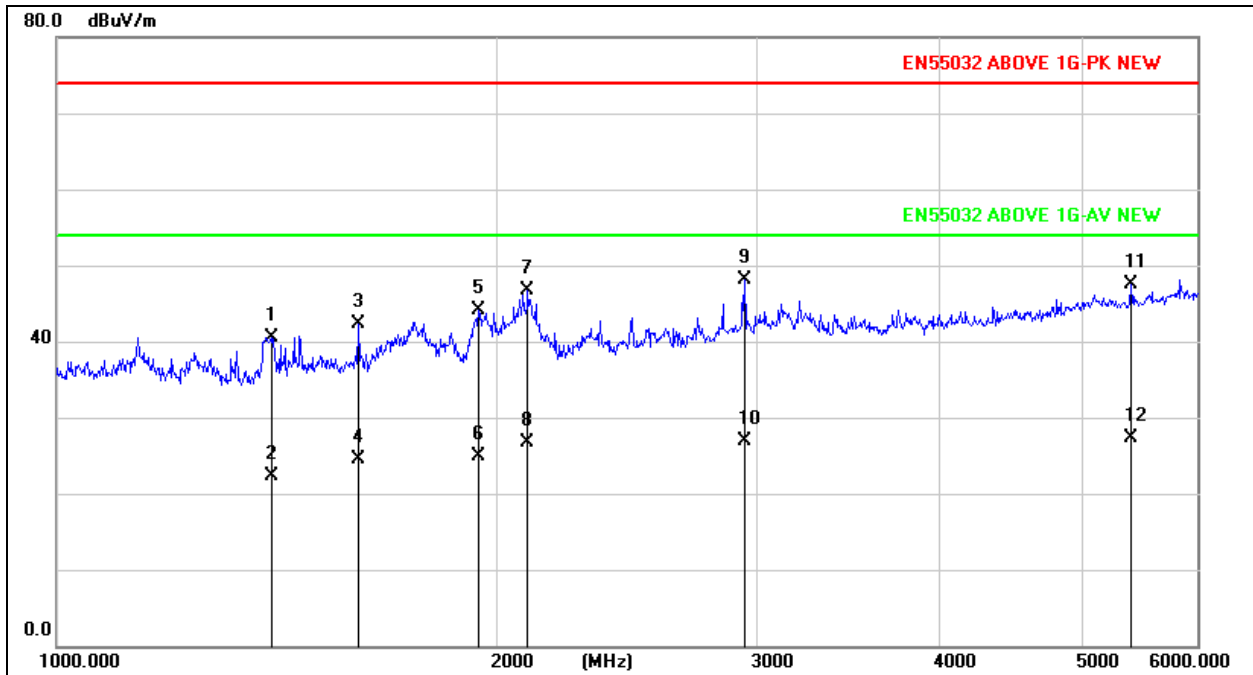

- Remark:
- Factor = Antenna Factor + Cable Loss – Pre-amplifier.
 - Measurement = Reading Level + Correct Factor
 - Over = Measurement - Limit

No. Mk.	Freq. MHz	Reading Level dBuV	Correct Factor dB	Measure- ment dBuV/m	Limit dB/m	Over dB	Detector	Antenna Height cm	Table Degree	Comment
1	1400.530	60.21	-19.66	40.55	74.00	-33.45	peak			
2	1400.530	41.96	-19.66	22.30	54.00	-31.70	AVG			
3	1607.719	61.58	-19.22	42.36	74.00	-31.64	peak			
4	1607.719	43.72	-19.22	24.50	54.00	-29.50	AVG			
5	1940.510	62.54	-18.52	44.02	74.00	-29.98	peak			
6	1940.510	43.42	-18.52	24.90	54.00	-29.10	AVG			
7	2095.928	64.74	-17.98	46.76	74.00	-27.24	peak			
8	2095.928	44.78	-17.98	26.80	54.00	-27.20	AVG			
9 *	2945.949	62.31	-14.24	48.07	74.00	-25.93	peak			
10	2945.949	41.16	-14.24	26.92	54.00	-27.08	AVG			
11	5407.773	55.72	-8.27	47.45	74.00	-26.55	peak			
12	5407.773	35.57	-8.27	27.30	54.00	-26.70	AVG			

9. Harmonic current emission(H)

9.1 Block Diagram of Test Setup

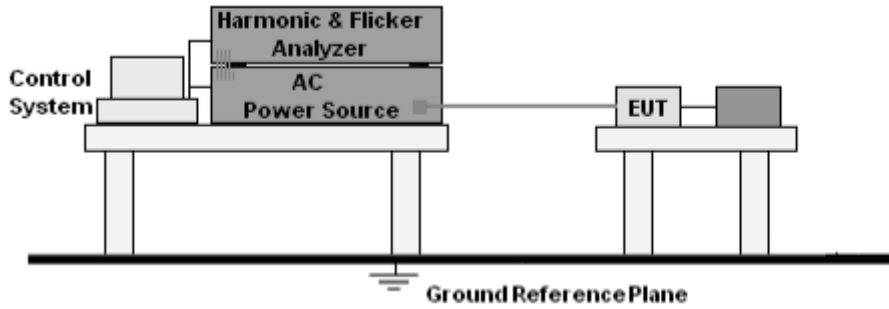

9.2 Limit

EN IEC 61000-3-2:2019

9.3 Test Procedure

- The Product was placed on the top of a non-conductive table above the ground and operated to produce the maximum harmonic components under normal operating conditions for each successive harmonic component in turn.
- The correspondent test program of test instrument to measure the current harmonics emanated from Product was chosen. The measure time shall be not less than the time necessary for the Product to be exercised.

9.4 Test Results

Not applicable

As specified on section 7 and above figure of EN 61000-3-2, the limits are not specified for equipment with a rated power of 75W or less. The EUT meets the above condition, so it conforms to EN 61000-3-2.

10. Voltage Fluctuations & Flicker (F)

10.1 Block Diagram of Test Setup

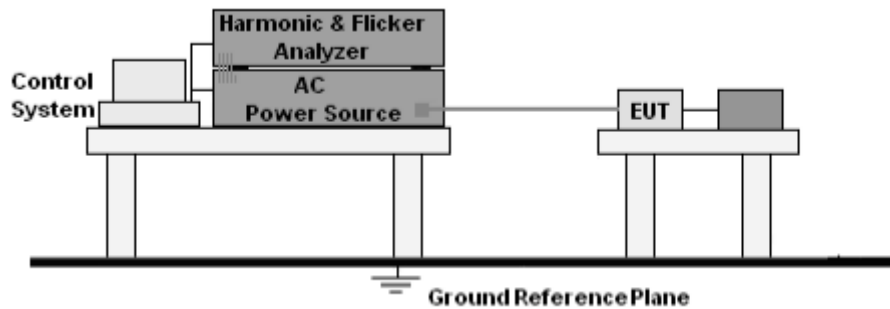

10.2 Limit

EN 61000-3-3:2013+A1:2019

10.3 Test Procedure

- The Product was placed on the top of a non-conductive table above the ground and operated to produce the most unfavorable sequence of voltage changes under normal operating conditions.
- During the flick test, the measure time shall include that part of whole operation cycle in which the Product produce the most unfavorable sequence of voltage changes. The observation period for short-term flicker indicator is 10 minutes and the observation period for long-term flicker indicator is 2 hours.

10.4 Test Results

Temperature:	26 °C	Relative Humidity:	54%
Pressure:	101kPa	Test Mode:	Mode 1
Test Voltage :	AC 230V/50Hz		

Test Data of Voltage Fluctuation and Flicker

Final Test Result **Pass**
 Nominal Voltage 230 V
 Nominal Frequency 50 Hz
 Plt Test Duration 600 s
 Flicker Margin 100 %
 d Measurement Margin 100 %

Segment	Pst	dmax(%)	dc(%)	d(t)>3.3%(ms)	Judge
Limit	1.000	4.000	3.300	500	
Seg. 1	0.018	0.017	0.004	0	Pass

Plt	Value	Judge
Limit	0.650	
Measurement	0.008	Pass

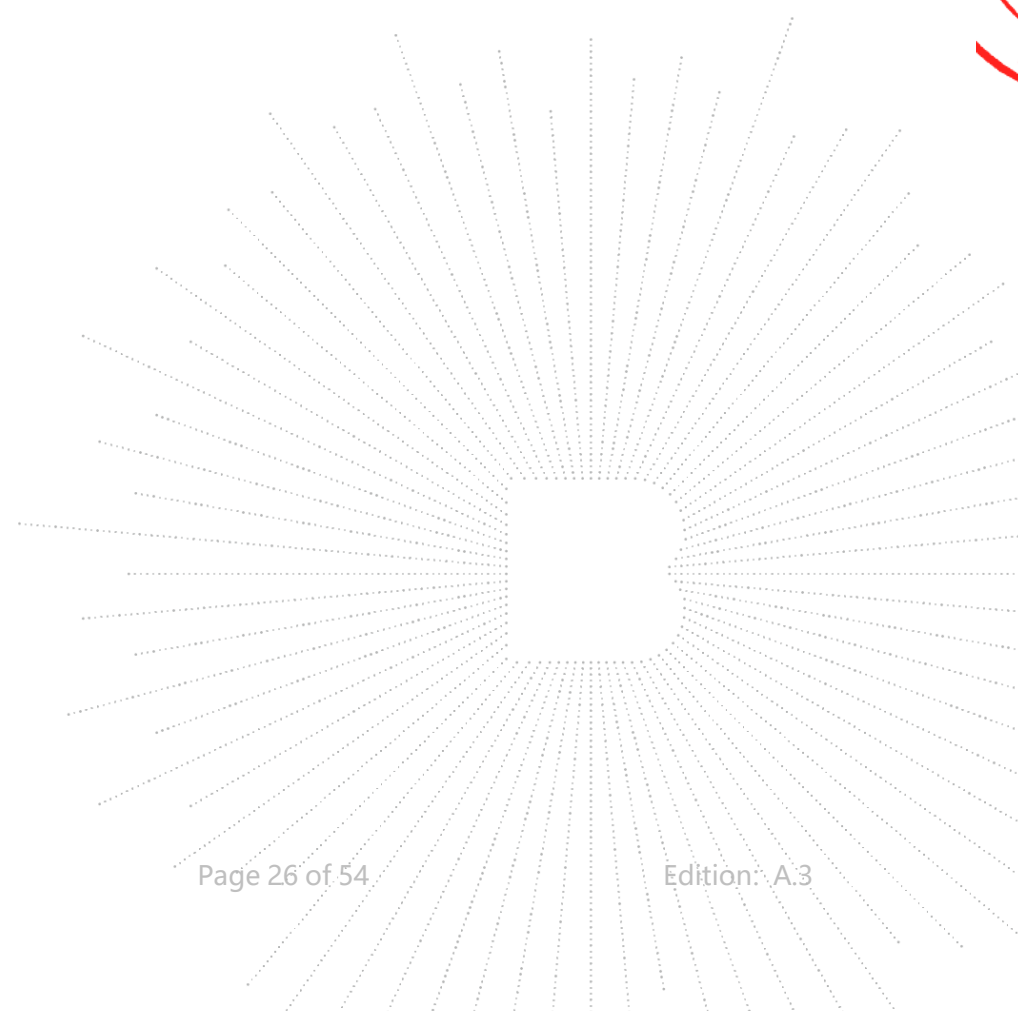

11. Immunity Test of General the Performance Criteria

According To EN 301489 -17 standard, The General Performance Criteria as Following:

Criteria	During test	After test (i.e. as a result of the application of the test)
A	Shall operate as intended. (see note). Shall be no loss of function. Shall be no unintentional transmissions.	Shall operate as intended. Shall be no degradation of performance. Shall be no loss of function. Shall be no loss of critical stored data.
B	May be loss of function.	Functions shall be self-recoverable. Shall operate as intended after recovering. Shall be no loss of critical stored data.
C	May be loss of function.	Functions shall be recoverable by the operator. Shall operate as intended after recovering. Shall be no loss of critical stored data.

NOTE: Operate as intended during the test allows a level of degradation in accordance with Minimum performance level.

Minimum performance level

For equipment that supports a PER or FER, the minimum performance level shall be a PER or FER less than or equal to 10 %.

For equipment that does not support a PER or a FER, the minimum performance level shall be no loss of the wireless transmission function needed for the intended use of the equipment.

Performance criteria for Continuous phenomena

The performance criteria A shall apply.

Where the EUT is a transmitter in standby mode, unintentional transmission shall not occur during the test.

Where the EUT is a transceiver in receive mode, unintentional transmission shall not occur during the test.

Performance criteria for Transient phenomena

The performance criteria B shall apply, except for voltage dips greater than or equal to 100 ms and voltage interruptions of 5 000 ms duration, for which performance criteria C shall apply.

Where the EUT is a transmitter in standby mode, unintentional transmission shall not occur as a result of the application of the test.

Where the EUT is a transceiver in receive mode, unintentional transmission shall not occur as a result of the application of the test.

C T
3C
PR
字测

12. Electrostatic Discharge (ESD)

12.1 Test Specification

Test Port	:	Enclosure port
Discharge Impedance	:	330 ohm / 150 pF
Discharge Mode	:	Single Discharge
Discharge Period	:	one second between each discharge

12.2 Block Diagram of Test Setup

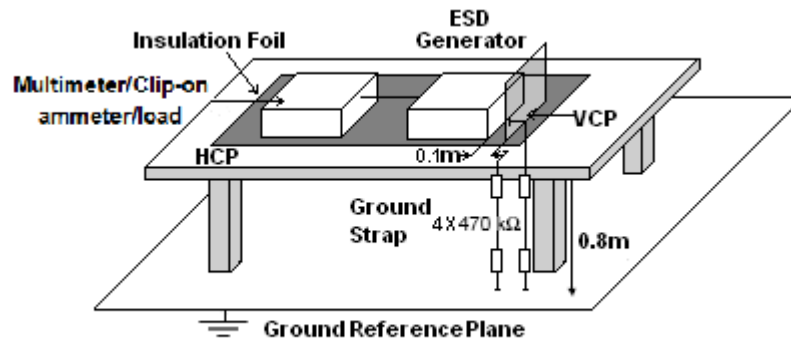

12.3 Test Procedure

- Electrostatic discharges were applied only to those points and surfaces of the Product that are accessible to users during normal operation.
- The test was performed with at least ten single discharges on the pre-selected points in the most sensitive polarity.
- The time interval between two successive single discharges was at least 1 second.
- The ESD generator was held perpendicularly to the surface to which the discharge was applied and the return cable was at least 0.2 meters from the Product.
- Contact discharges were applied to the non-insulating coating, with the pointed tip of the generator penetrating the coating and contacting the conducting substrate.
- Air discharges were applied with the round discharge tip of the discharge electrode approaching the Product as fast as possible (without causing mechanical damage) to touch the Product. After each discharge, the ESD generator was removed from the Product and re-triggered for a new single discharge. The test was repeated until all discharges were complete.

12.4 Test Results

Temperature:	26 °C	Relative Humidity:	54%
Pressure:	101kPa	Test Mode:	Mode 1
Test Voltage :	AC 230V/50Hz		

Mode	Air Discharge (Test result)								Contact Discharge (Test result)								Perform Criteria	Result (Pass/Fail)
	2		4		8		15		2		4		6		8			
Test Location	+	-	+	-	+	-	+	-	+	-	+	-	+	-	+	-		
HCP									A	A	A	A					TT&TR	PASS
VCP									A	A	A	A					TT&TR	PASS
Slots	A	A	A	A	A	A											TT&TR	PASS
HDMI	A	A	A	A	A	A											TT&TR	PASS
DP, USB	A	A	A	A	A	A											TT&TR	PASS
Conductive Surfaces									A	A	A	A					TT&TR	PASS

Note:

- 1) P/N denotes the Positive/Negative polarity of the output voltage.
- 2) Test condition:
 Direct / Indirect (HCP/VCP) discharges: Minimum 50 times (Positive/Negative) at each point.
 Air discharges: Minimum 10 times (Positive/Negative) at each point.
- 3) N/A - denotes test is not applicable in this test report
- 4) There was not any unintentional transmission in standby mode



13. Continuous RF Electromagnetic Field Disturbances(RS)

13.1 Test Specification

Test Port	: Enclosure port
Step Size	: 1%
Modulation	: 1kHz, 80% AM
Dwell Time	: 1 second
Polarization	: Horizontal & Vertical

13.2 Block Diagram of Test Setup

Below 1GHz:

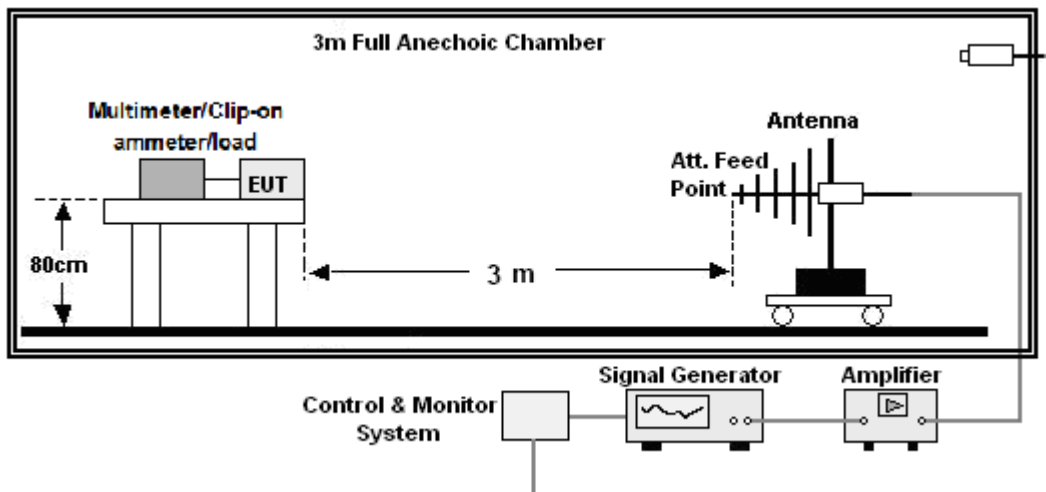

Above 1GHz:

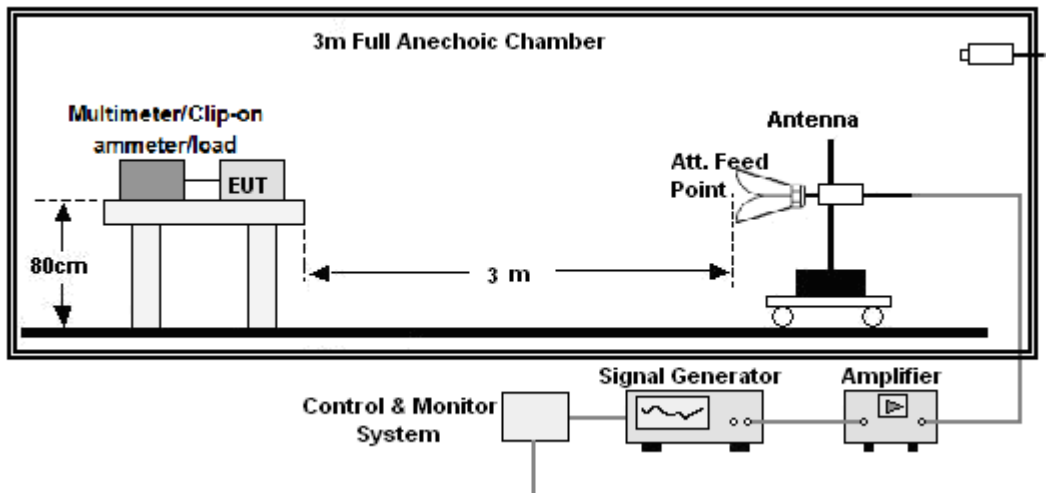

13.3 Test Procedure

- a. The testing was performed in a fully-anechoic chamber. The transmit antenna was located at a distance of 3 meters from the Product.
- b. The frequency range is swept from 80MHz to 6000MHz, with the signal 80% amplitude modulated with a 1 kHz sine wave, and the step size was 1%.
- c. The dwell time at each frequency shall not be less than the time necessary for the EUT to be exercised and to be able to respond, but should not exceed 5 s at each of the frequencies during the scan.
- d. The test was performed with the Product exposed to both vertically and horizontally polarized fields on each of the four sides.
- e. For Broadcast reception function: Group 2 not apply in this test.

13.4 Test Results

Temperature:	26 °C	Relative Humidity:	54%
Pressure:	101kPa	Test Mode:	Mode 1
Test Voltage :	AC 230V/50Hz		

Frequency Range (MHz)	RF Field Position	R.F.Field Strength	Azimuth	Perform Criteria	Test Result	Result (Pass/Fail)
80~6000	H / V	3 V/m (rms) AM Modulated 1000Hz, 80%	Front	CT&CR	A	PASS
			Rear			
			Left			
			Right			

Note:

- 1) P/N denotes the Positive/Negative polarity of the output voltage.
- 2) N/A - denotes test is not applicable in this test report.
- 3) There was no change operated with initial operating during the test.
- 4) There was not any unintentional transmission in standby mode

14. Electrical fast transients/burst (EFT)

14.1 Test Specification

Test Port	: input AC power port
Impulse Frequency	: 5 kHz
Impulse Wave-shape	: 5/50 ns
Burst Duration	: 15 ms
Burst Period	: 300 ms
Test Duration	: 2 minutes per polarity

14.2 Block Diagram of EUT Test Setup

For input AC power port:

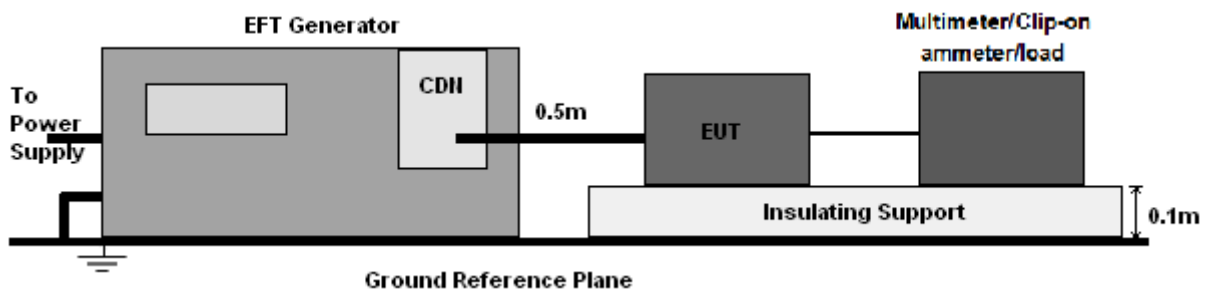

14.3 Test Procedure

- The Product and support units were located on a non-conductive table above ground reference plane.
- A 0.5m-long power cord was attached to Product during the test.

14.4 Test Results

Temperature:	26 °C	Relative Humidity:	54%
Pressure:	101kPa	Test Mode:	Mode 1
Test Voltage :	AC 230V/50Hz		

Injection Line	Voltage (kV)	Injected Method	Actual criterion	Required performance criterion	Result (Pass/Fail)
<input checked="" type="checkbox"/> AC mains power ports	± 1	<input checked="" type="checkbox"/> CDN <input type="checkbox"/> Direct injection <input type="checkbox"/> Capacitive coupling clamp	A (CT&CR)	B	Pass
<input checked="" type="checkbox"/> Signal Line	±0.5	<input type="checkbox"/> CDN <input type="checkbox"/> Direct injection <input checked="" type="checkbox"/> Capacitive coupling clamp	A (CT&CR)	B	Pass

Note:

- 1) P/N denotes the Positive/Negative polarity of the output voltage.
- 2) N/A - denotes test is not applicable in this test report.
- 3) There was not any unintentional transmission in standby mode
- 4) *During the test, the product disconnects the charging connection, and the charging connection will be restored automatically after the interference end.

C T
 30
 PPR
 检测

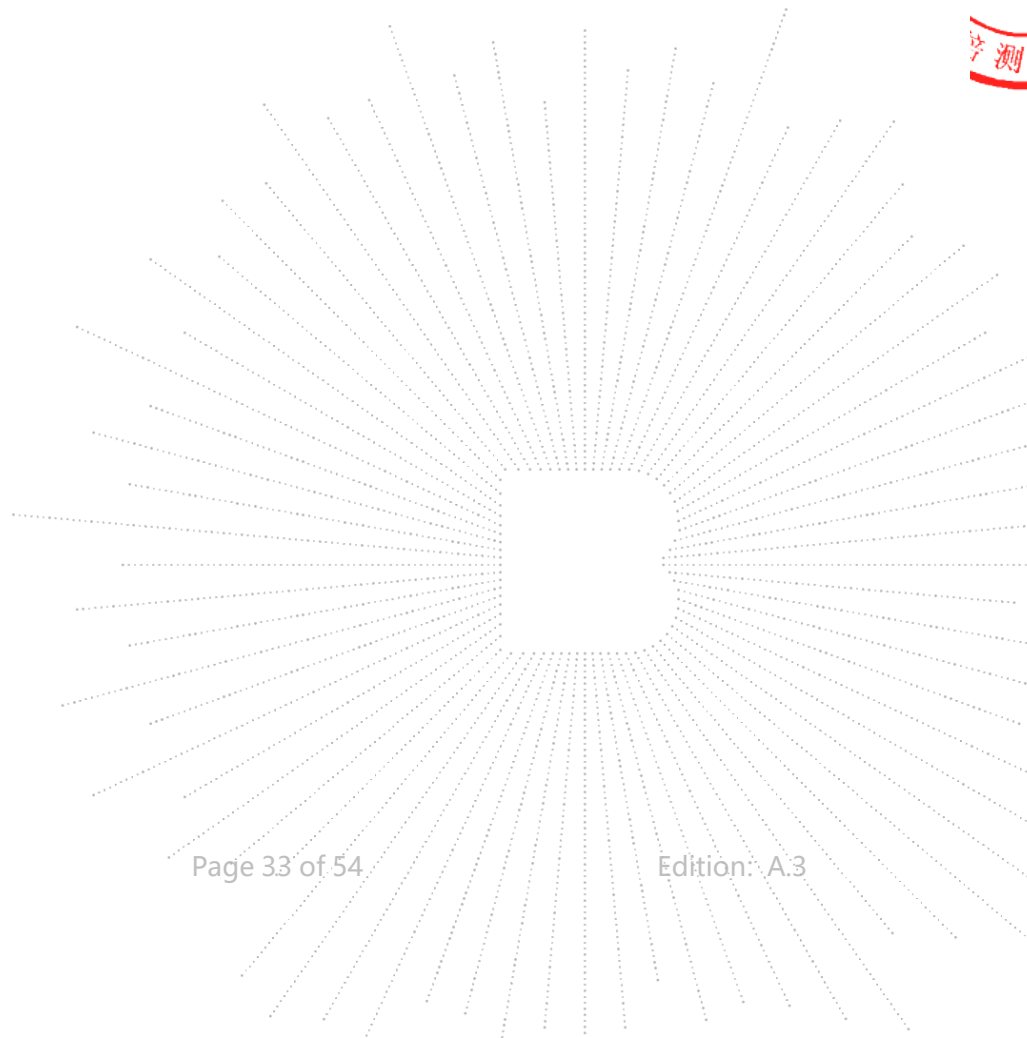

15. Surges Immunity Test

15.1 Test Specification

Test Port	: input AC power port
Wave-Shape	: Open Circuit Voltage - 1.2 / 50 us Short Circuit Current - 8 / 20 us
Pulse Repetition Rate	: 1 pulse / min.
Phase Angle	: 0° / 90° / 180° / 270°
Test Events	: 5 pulses (positive & negative) for each polarity

15.2 Block Diagram of EUT Test Setup

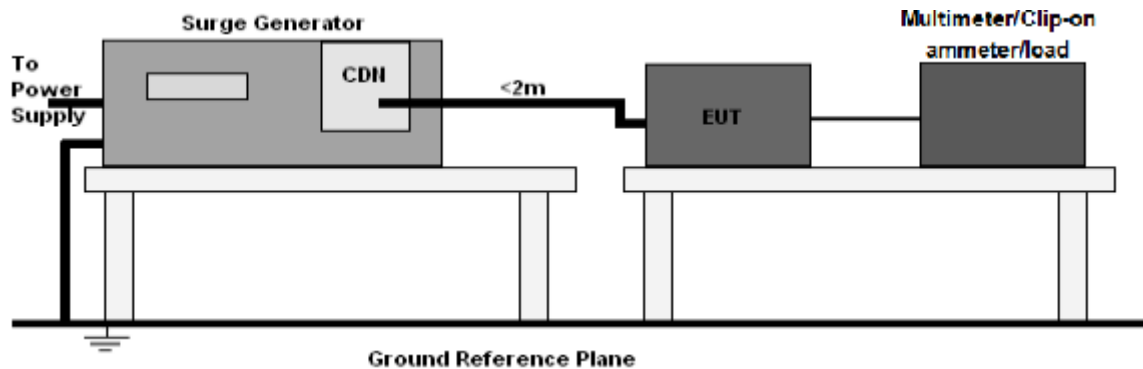

15.3 Test Procedure

- The surge is to be applied to the Product power supply terminals via the capacitive coupling network. Decoupling networks are required in order to avoid possible adverse effects on equipment not under test that may be powered by the same lines, and to provide sufficient decoupling impedance to the surge wave.
- The power cord between the Product and the coupling/decoupling networks shall be 2 meters in length (or shorter). Interconnection line between the Product and the coupling/decoupling networks shall be 2 meters in length (or shorter).

15.4 Test Result

Temperature:	26 °C	Relative Humidity:	54%
Pressure:	101kPa	Test Mode:	Mode 1
Test Voltage :	AC 230V/50Hz		

AC mains power ports:

Coupling Line	Voltage (kV)	Waveform (µs)	Polarity	Actual criterion	Required performance criterion	Result (Pass/Fail)
<input checked="" type="checkbox"/> Line to line	1	1.2/50 (8/20)	Pos./ Neg.	A (CT&CR)	B	Pass
<input checked="" type="checkbox"/> Line to earth	2	1.2/50 (8/20)	Pos./ Neg.	A (CT&CR)	B	Pass

Analogue/digital data ports:

Port type	Coupling Line	Voltage (kV)	Waveform (µs)	Polarity	Actual criterion	Required performance criterion	Result (Pass/Fail)
<input checked="" type="checkbox"/> Unshielded symmetrical (Wired network port)	Lines to ground	0.5	1.2/50 (8/20)	Pos./ Neg.	A (CT&CR)	B	Pass
<input type="checkbox"/> Unshielded symmetrical (Signal Line)	Lines to ground	1	10/700 (5/320)	Pos./ Neg.	N/A	B	N/A
<input type="checkbox"/> Unshielded symmetrical	Lines to ground	0.5	10/700 (5/320)	Pos./ Neg.	N/A	B	N/A
<input type="checkbox"/> Coaxial or shielded (.....)	Shield to ground	0.5	1.2/50 (8/20)	Pos./ Neg.	N/A	B	N/A

Note:

- 1) Polarity and Numbers of Impulses: 5 Pst / Ngt at each tested mode
- 2) N/A - denotes test is not applicable in this Test Report
- 3) There was not any unintentional transmission in standby mode



16. Continuous Induced RF Disturbances (CS)

16.1 Test Specification

Test Port	:	input AC. power port
		analogue/digital data port
Step Size	:	1%
Modulation	:	1kHz, 80% AM
Dwell Time	:	1 second

16.2 Block Diagram of EUT Test Setup

For input AC power port:

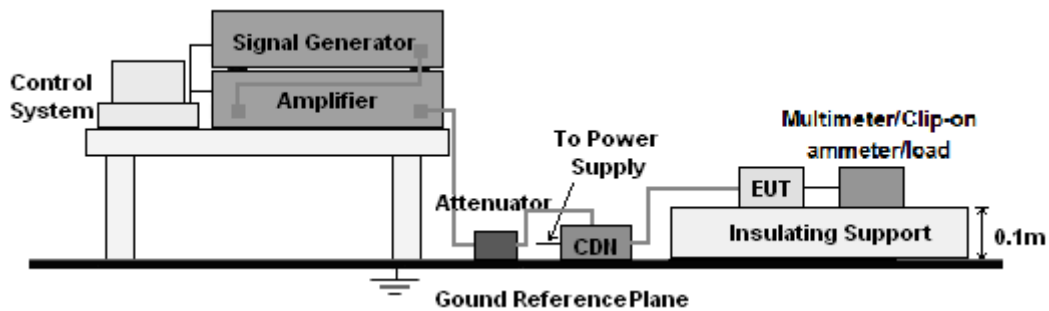

16.3 Test Procedure

For input AC power port:

- The Product and support units were located at a ground reference plane with the interposition of a 0.1 m thickness insulating support and the CDN was located on GRP directly.
- The frequency range is swept from 150 kHz to 10MHz, 10MHz to 30MHz, 30MHz to 80MHz with the signal 80% amplitude modulated with a 1 kHz sine wave, and the step size was 1% of fundamental.
- The dwell time at each frequency shall be not less than the time necessary for the Product to be able to respond.

16.4 Test Result

Temperature:	26 °C	Relative Humidity:	54%
Pressure:	101kPa	Test Mode:	Mode 1
Test Voltage :	AC 230V/50Hz		

Range (MHz)	Levers (V)	Injection port	Coupling type	Actual criterion	Required performance criterion	Result (Pass/Fail)
0.15-80	3	<input checked="" type="checkbox"/> AC mains power ports	<input checked="" type="checkbox"/> CDN <input type="checkbox"/> EM Clamp <input type="checkbox"/> Current Clamp <input type="checkbox"/> Direct injection	A (CT&CR)	A	Pass
0.15-80	3	<input type="checkbox"/> DC network power ports	<input type="checkbox"/> CDN <input type="checkbox"/> EM Clamp <input type="checkbox"/> Current Clamp <input type="checkbox"/> Direct injection	N/A	N/A	N/A
0.15-80	3	<input type="checkbox"/> Analogue/digital data ports (Signal Line)	<input type="checkbox"/> CDN <input type="checkbox"/> EM Clamp <input type="checkbox"/> Current Clamp <input type="checkbox"/> Direct injection	N/A	N/A	N/A
0.15-80	3	<input checked="" type="checkbox"/> Analogue/digital data ports (network ports)	<input type="checkbox"/> CDN <input type="checkbox"/> EM Clamp <input checked="" type="checkbox"/> Current Clamp <input type="checkbox"/> Direct injection	A (CT&CR)	N/A	Pass

Note:

- 1) "A" stand for, during test, operate as intended no loss of function, no degradation of performance, no unintentional transmissions and after test, no degradation of performance, no loss of function, no loss of stored data or user programmable functions

17. Voltage dips and interruptions (DIPS)

17.1 Test Specification

Test Port	: input AC power port
Phase Angle	: 0°, 180°
Test cycle	: 3 times

17.2 Block Diagram of EUT Test Setup

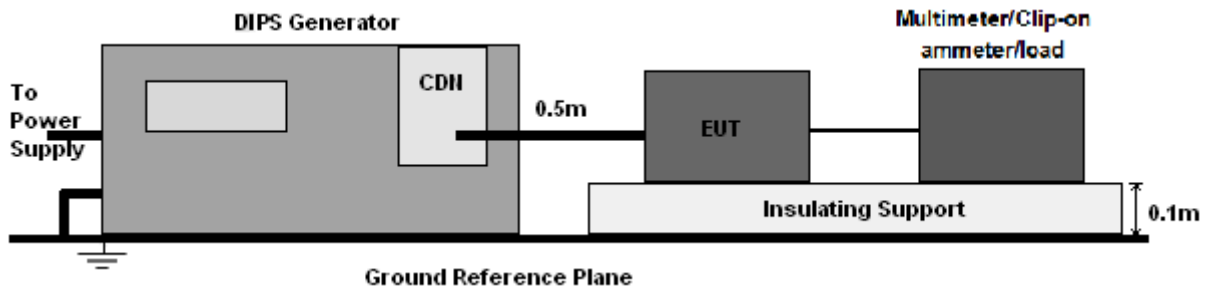

17.3 Test Procedure

- The Product and support units were located on a non-conductive table above ground floor.
- Set the parameter of tests and then perform the test software of test simulator.
- Conditions changes to occur at 0 degree crossover point of the voltage waveform.



17.4 Test Result

Temperature:	26 °C	Relative Humidity:	54%
Pressure:	101kPa	Test Mode:	Mode 1
Test Voltage :	AC 230V/50Hz		

Voltage Reduction	Duration (ms)	Perform Criteria	Test Result	Judgment
Voltage dip 0%	10	TT&TR	A	PASS
Voltage dip 0%	20	TT&TR	A	PASS
Voltage dip 70%	500	TT&TR	C*	PASS
Voltage interruptions	5000	TT&TR	C*	PASS

Note:

- 1) There was not any unintentional transmission in standby mode.
- 2) *:During the test, the product disconnects the charging connection, and the charging connection

C T
 3C
 PPR
 学测

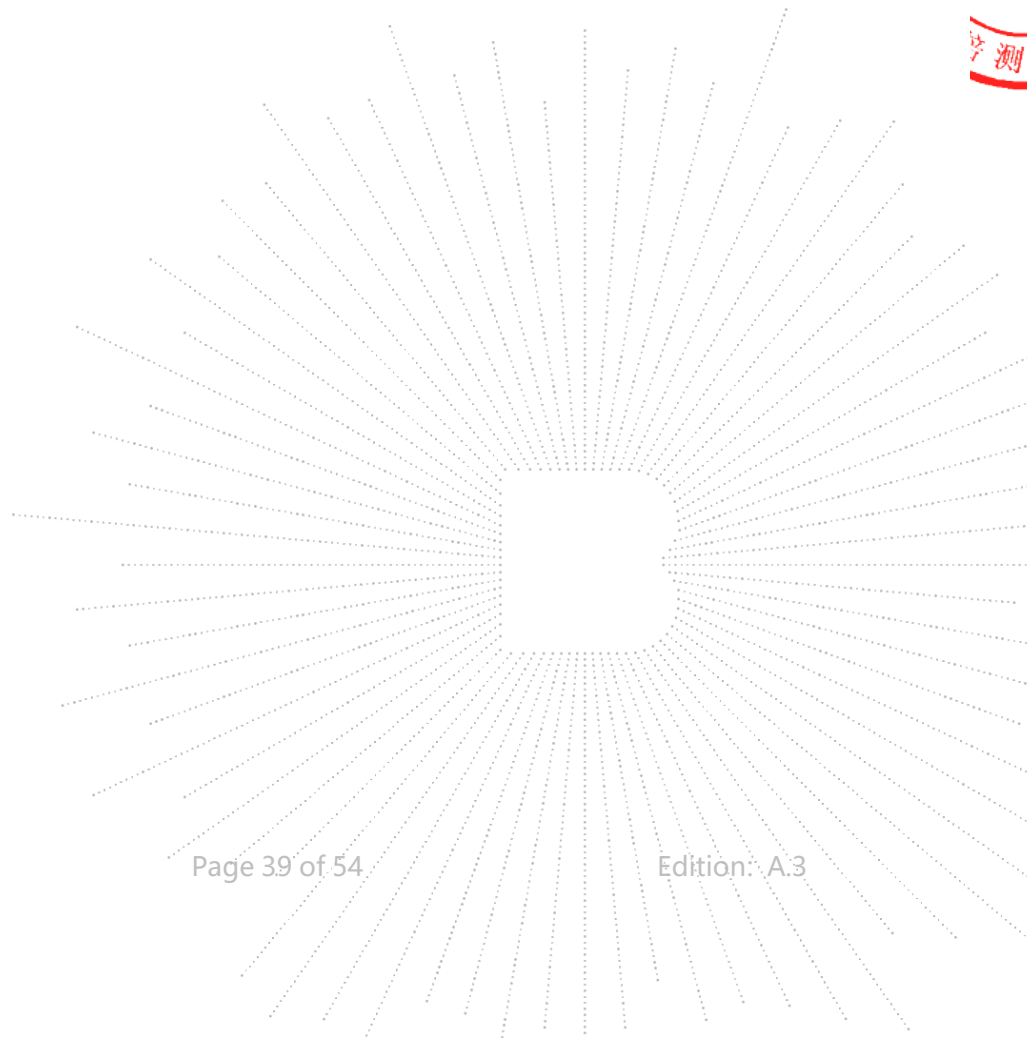

18. EUT Photographs

EUT Photo 1



EUT Photo 2



EUT Photo 3



EUT Photo 4



EUT Photo 5



EUT Photo 6

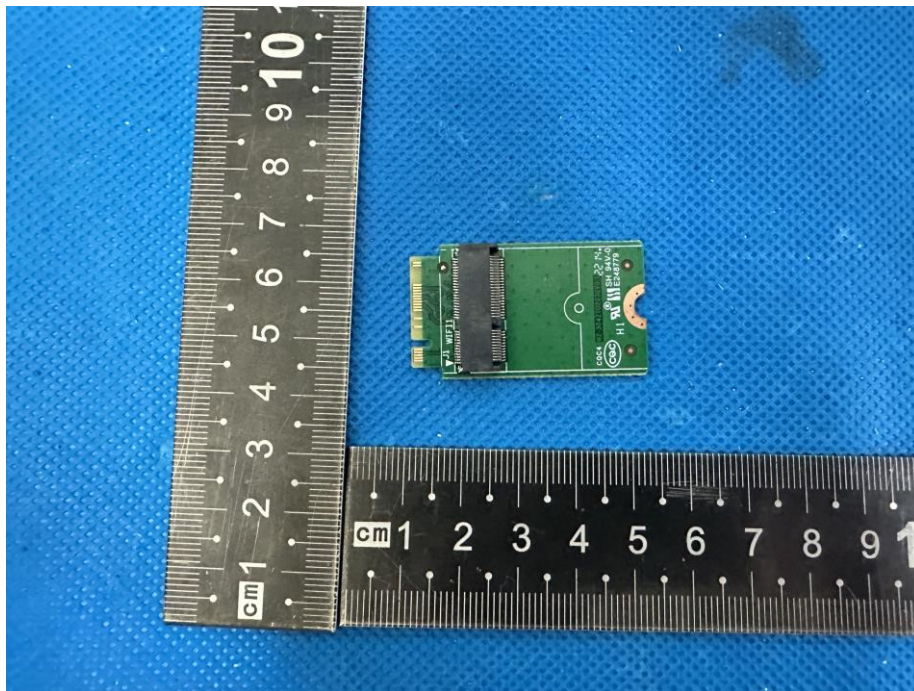

CO., LTD

EUT Photo 7

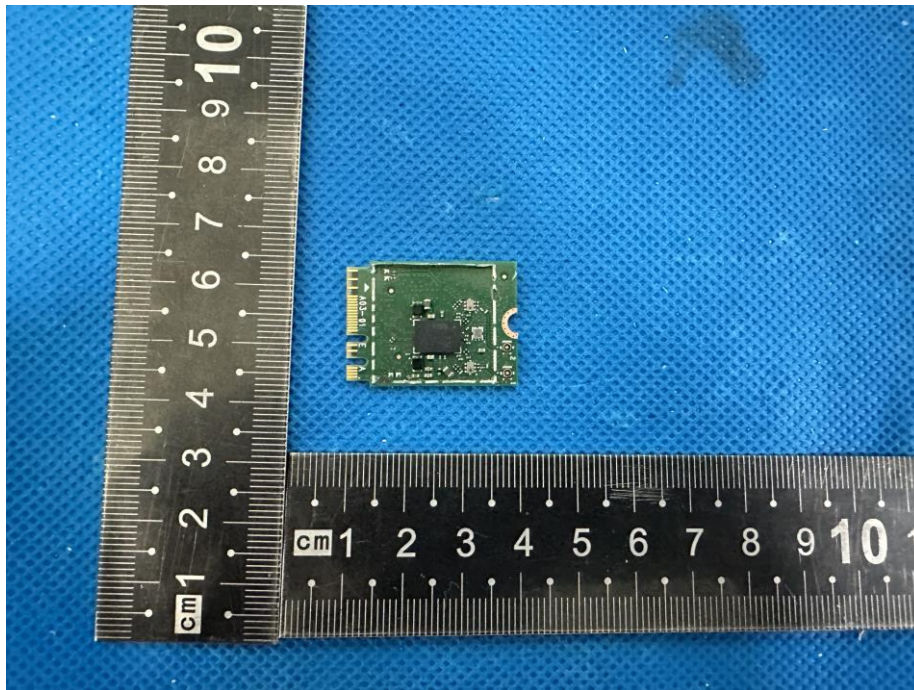

EUT Photo 8

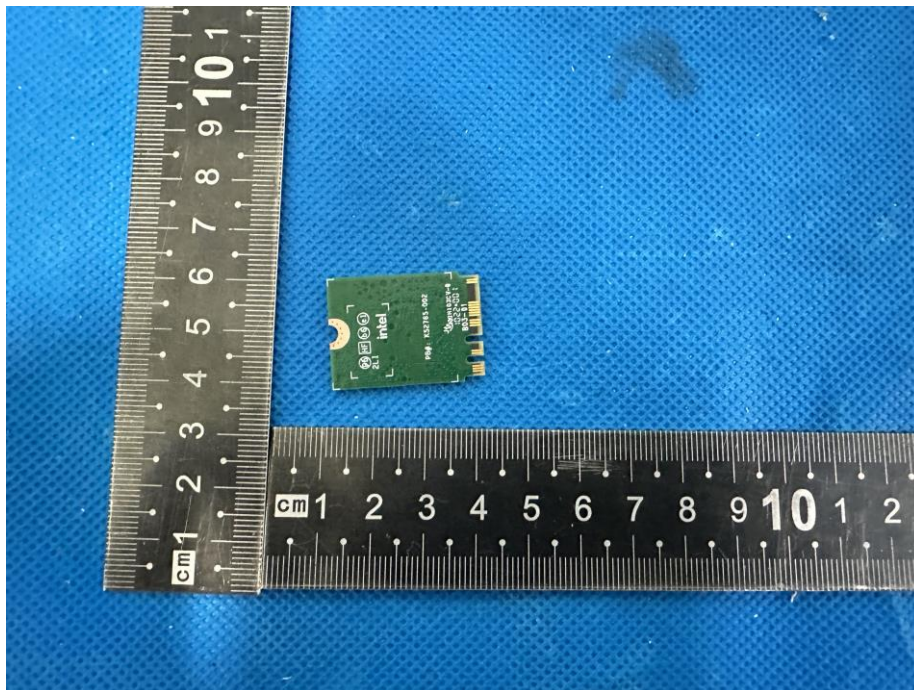

EUT Photo 9

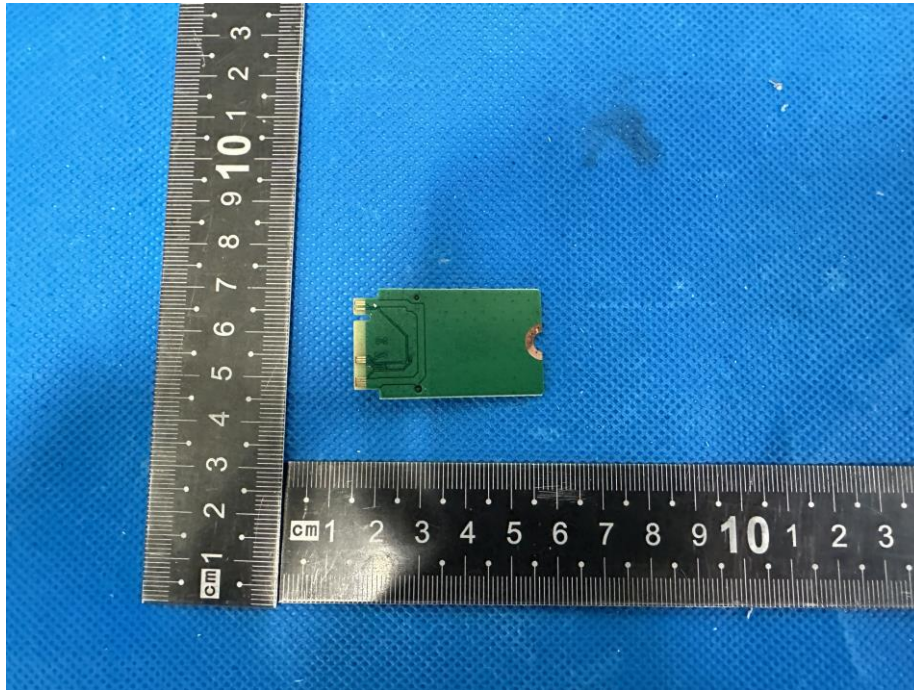

EUT Photo 10



EUT Photo 11

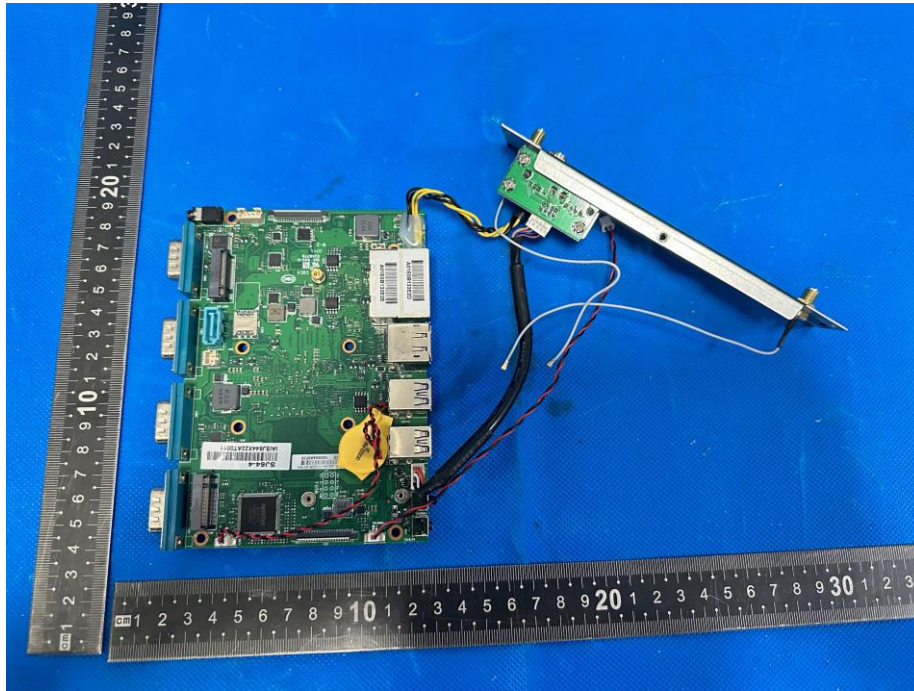

EUT Photo 12

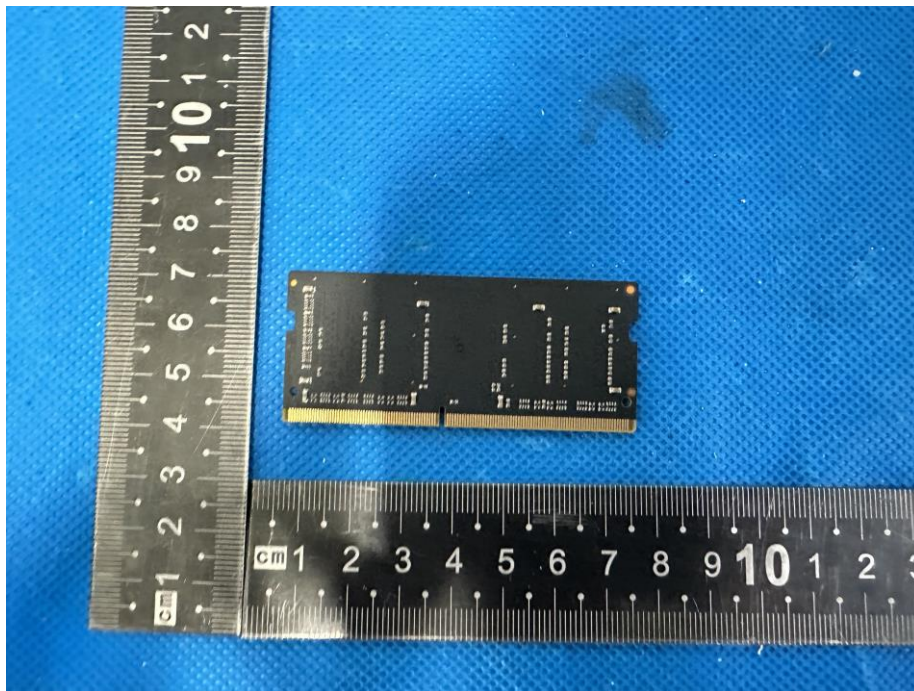

C T
30
PPR
检测

EUT Photo 13

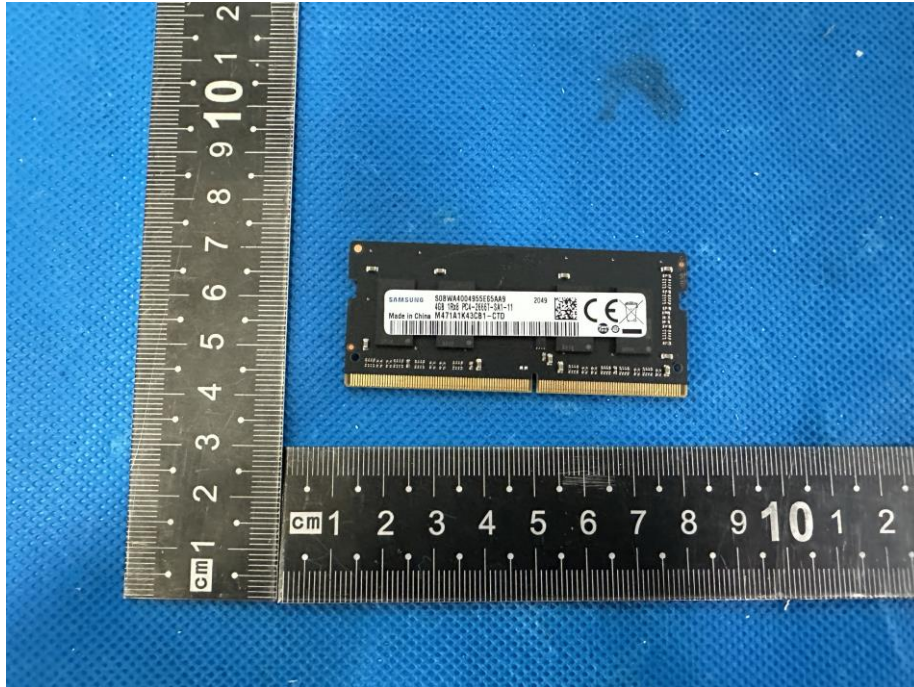

EUT Photo 14

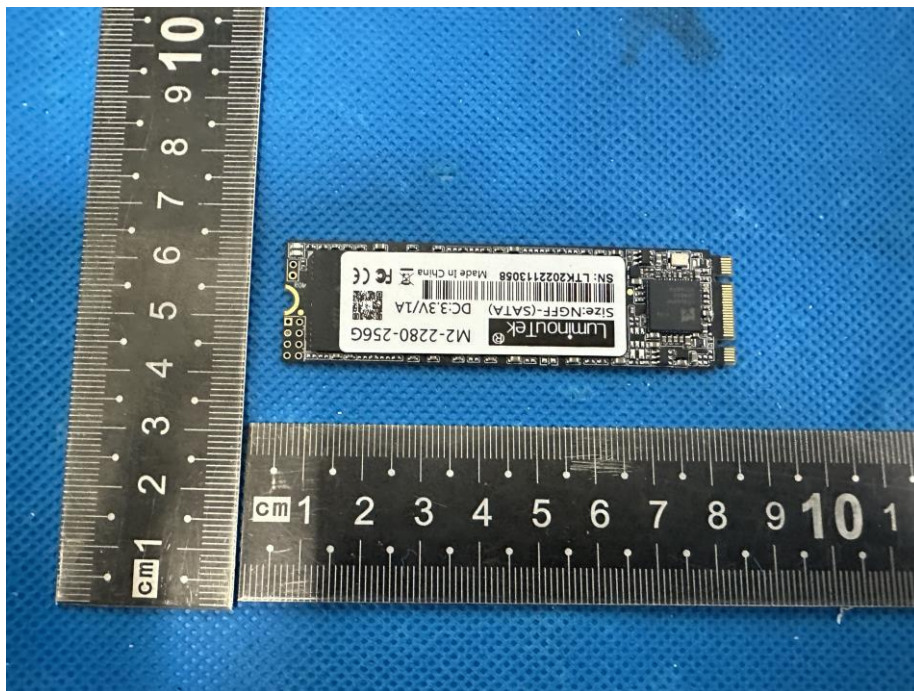

ECH
TC
OV
科

EUT Photo 15

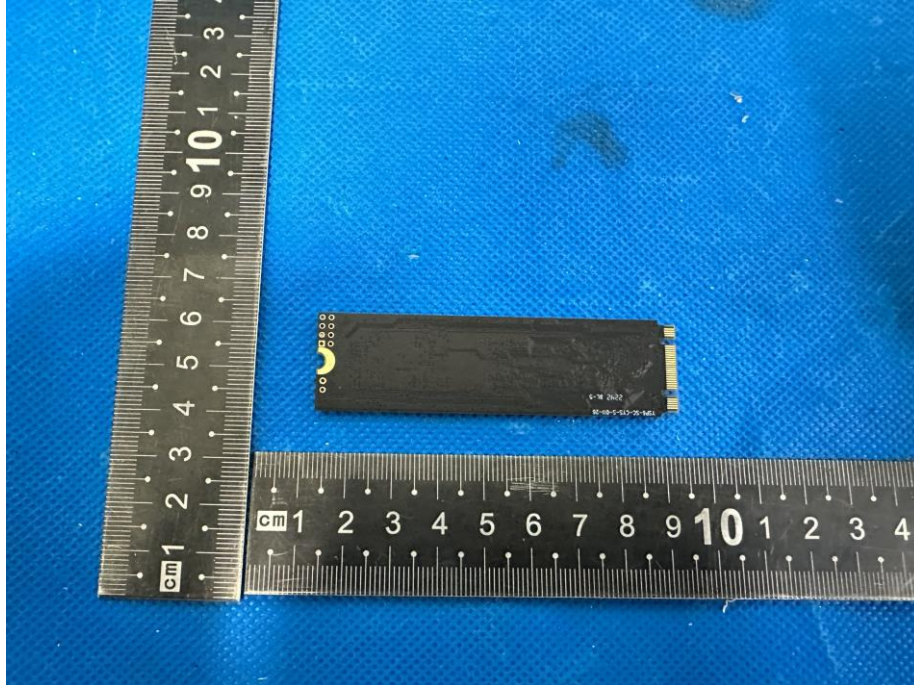

19. EUT Test Setup Photographs

Conducted emissions



Radiated emissions



AN CO., LTD



H/F

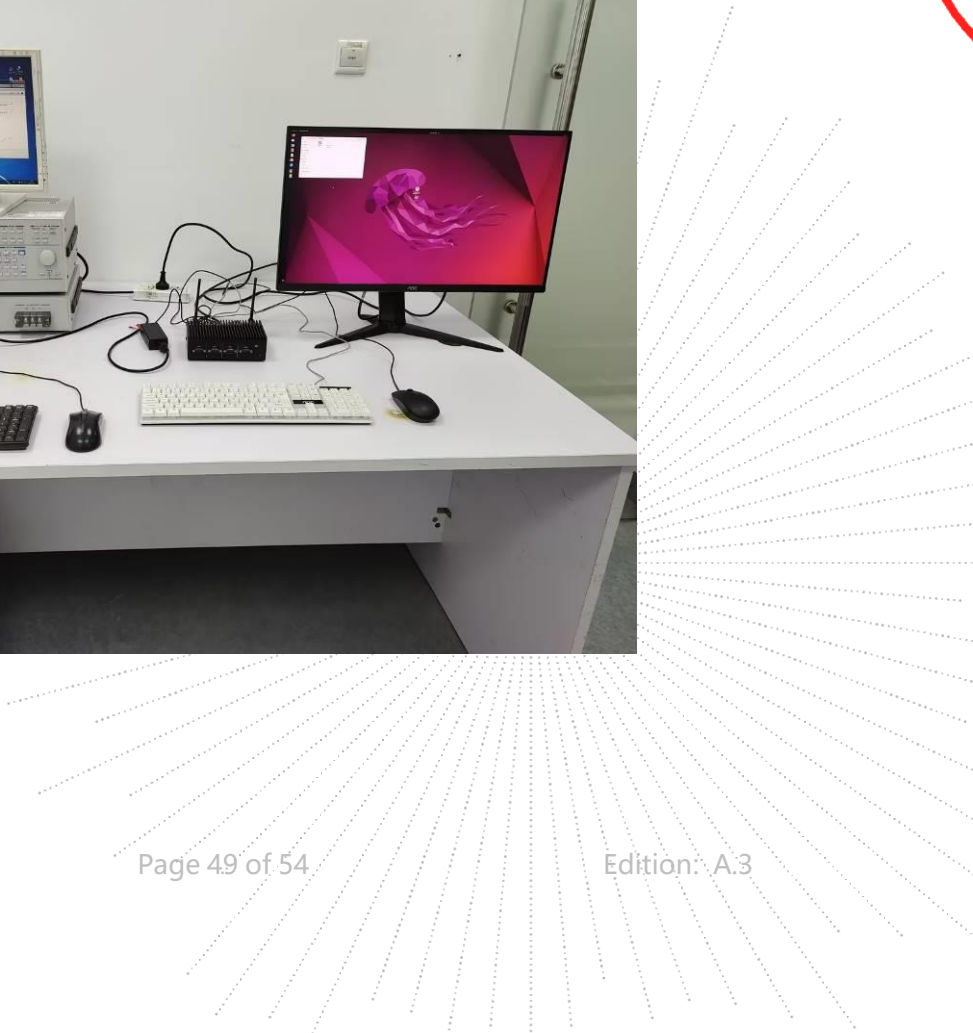

ESD



EFT



Surge



CS



C T
30
PPR
检测

Dips



Continuous RF Electromagnetic Field Disturbances

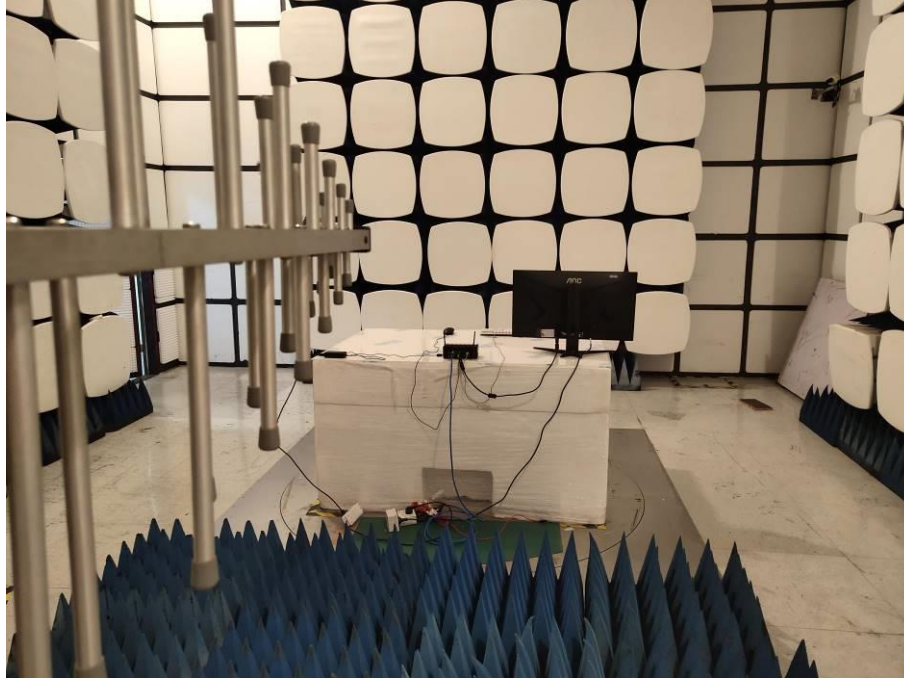

ECH
TC
OVB
科

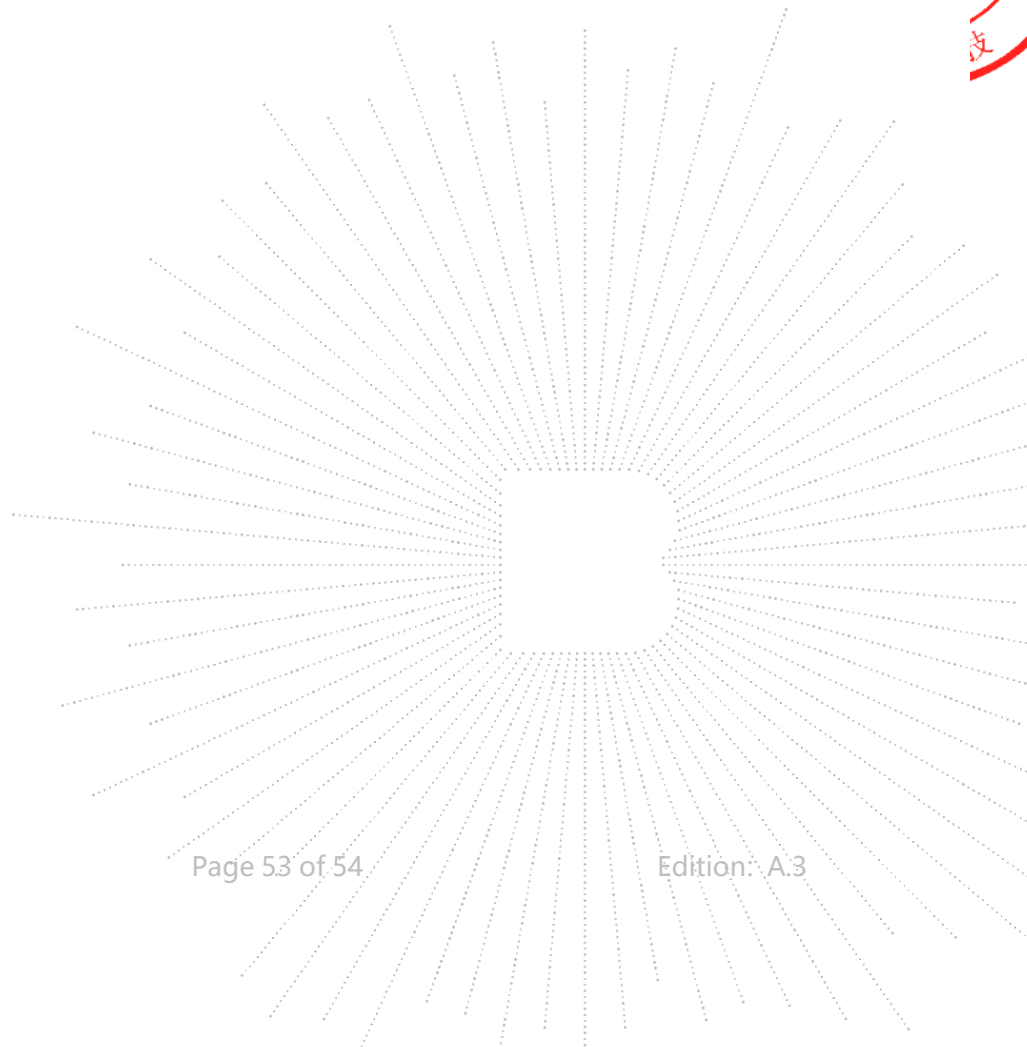
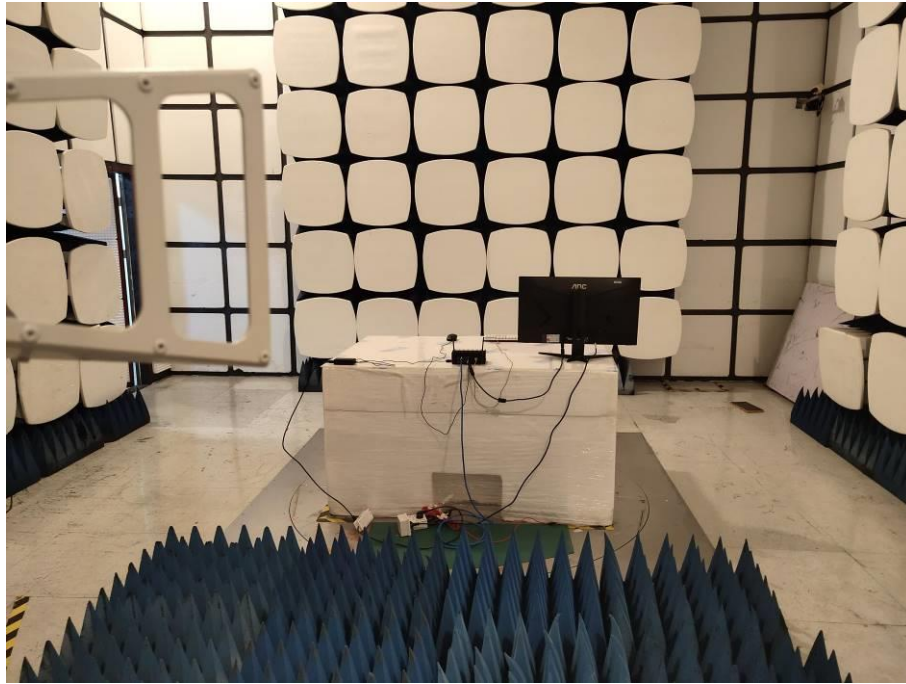

STATEMENT

- 1.The equipment lists are traceable to the national reference standards.
- 2.The test report can not be partially copied unless prior written approval is issued from our lab.
- 3.The test report is invalid without stamp of laboratory.
- 4.The test report is invalid without signature of person(s) testing and authorizing.
- 5.The test process and test result is only related to the Unit Under Test.
- 6.The quality system of our laboratory is in accordance with ISO/IEC17025.
- 7.If there is any objection to report, the client should inform issuing laboratory within 15 days from the date of receiving test report.

Address:

1st floor, building 2, Huayou Industrial Zone, Yousong Road, Fukang community, Longhua street, Longhua District, Shenzhen, P. R. China

TEL: 400-788-9558

P.C.: 518103

FAX: 0755-33229357

Website: <http://www.chnbctc.com>

E-Mail: bctc@bctc-lab.com.cn

***** END *****